

FAX

Fill out the form and fax a copy to our VP sales division.

下記シートをコピーの上必要事項を記入し、弊社VP営業部にFAXください。

Company name 御社名			Date 作成日		
Company address 御住所〒			Telephone 電話		
Your department 貴部署名			F A X		
Your name 御担当	E-Mail				
Your product requirement 要求内容	<input type="checkbox"/> Bare shaft vacuum pump 本体のみ <input type="checkbox"/> with Drivers 駆動完成品 <input type="checkbox"/> Once through package 1パスパッケージ <input type="checkbox"/> Recircuration package 循環パッケージ <input type="checkbox"/> Others その他()				
Application 用途					
Experience with our product 実績の有無	<input type="checkbox"/> Yes 有 <input type="checkbox"/> No 無		Time of delivery 納入時期 ()		
	Mfg. No. 製作番号 ()		Model 口径形式 ()		
Quantity 台数					
Inlet pressure 吸込圧力	<input type="checkbox"/> kPa (<input type="checkbox"/> abs <input type="checkbox"/> G)				
Discharge pressure 吐出し圧力	<input type="checkbox"/> kPa (<input type="checkbox"/> abs <input type="checkbox"/> G)				
Inlet capacity 吸込量	<input type="checkbox"/> m ³ /min <input type="checkbox"/> kg/h (kg/h requires average molecular weight kg/hの場合平均分子量が必要)				
Handled gas 取扱ガス	<input type="checkbox"/> Air 空気 <input type="checkbox"/> Air-saturated water vapor 空気-水蒸気飽和 <input type="checkbox"/> Others その他()				
Gas temperature ガス温度	°C (Maximum 80°C)				
Seal liquid 封液	Name 名称	<input type="checkbox"/> Water 水 <input type="checkbox"/> Others その他()			
	Temperature 温度	°C			
	Specific gravity 密度	(Not required for water 水の場合不要です) kg/m ³			
	Specific heat 比熱	(Not required for water 水の場合不要です) kJ/kg・K			
	Viscosity 粘度	(Not required for water 水の場合不要です) mPa・s			
Thermal conductivity 熱伝導率	(Only when heat exchanger is needed. Not required for water 熱交換器が必要な場合のみ。水の場合不要です) W/m・K				
Power supply frequency 電源周波数	<input type="checkbox"/> 50Hz <input type="checkbox"/> 60Hz				
Voltage 電圧					
Motor type モーター形式	(ex. IPxx Exd IIC T4)				
Pump material ポンプ材質	<input type="checkbox"/> Standard 標準 <input type="checkbox"/> See below 下記				
Main parts 主要部品	Casing ケーシング			Port plate 仕切板	
	Side cover サイドカバー			Shaft 主軸	
	Impeller 羽根車			O ring ガasket類	
Shaft seal type 軸封部形式	<input type="checkbox"/> Gland packing グランドパッキン <input type="checkbox"/> Single mechanical seal シングルメカ <input type="checkbox"/> Double mechanical seal ダブルメカ				
Shaft seal material 軸封部材質	<input type="checkbox"/> Standard 標準 <input type="checkbox"/> Request 指定()				
Accessories 付属品					
Common base 共通ベース	<input type="checkbox"/> Yes 要 <input type="checkbox"/> No 否	Temporary strainer テンポリスレーナ	<input type="checkbox"/> Yes 要 <input type="checkbox"/> No 否	Seal liquid pressure gauge 封液圧力計	<input type="checkbox"/> Yes 要 <input type="checkbox"/> No 否
Foundation bolt 基礎ボルト	<input type="checkbox"/> Yes 要 <input type="checkbox"/> No 否	Gas check valve ガス入口逆止弁	<input type="checkbox"/> Yes 要 <input type="checkbox"/> No 否	Temperature gauge 温度計	<input type="checkbox"/> Yes 要 <input type="checkbox"/> No 否
Coupling 軸継手	<input type="checkbox"/> Yes 要 <input type="checkbox"/> No 否	Seal liquid flow meter 封液流量計	<input type="checkbox"/> Yes 要 <input type="checkbox"/> No 否	Level gauge 液面計	<input type="checkbox"/> Yes 要 <input type="checkbox"/> No 否
Safety cover 安全カバー	<input type="checkbox"/> Yes 要 <input type="checkbox"/> No 否	Special tool 特殊分解工具	<input type="checkbox"/> Yes 要 <input type="checkbox"/> No 否	Makeup valve 補給弁	<input type="checkbox"/> Yes 要 <input type="checkbox"/> No 否
Seal liquid control valve 封液調整弁	<input type="checkbox"/> Yes 要 <input type="checkbox"/> No 否	Gas ejector ガスエ젝タ	<input type="checkbox"/> Yes 要 <input type="checkbox"/> No 否	Seal liquid strainer 封液ストレーナ	<input type="checkbox"/> Yes 要 <input type="checkbox"/> No 否
Vacuum gauge with cock 真空計及びコック	<input type="checkbox"/> Yes 要 <input type="checkbox"/> No 否	Heat exchanger 熱交換器	<input type="checkbox"/> Yes 要 <input type="checkbox"/> No 否		
Separator tank セパレータータンク	<input type="checkbox"/> Yes 要 <input type="checkbox"/> No 否	Circulation pump 循環ポンプ	<input type="checkbox"/> Yes 要 <input type="checkbox"/> No 否		
Cooling water condition 冷却水条件	Name 名称			Specific gravity 密度	kg/m ³
	Temperature 温度	°C		Specific heat 比熱	kJ/kg・K
	Thermal conductivity 熱伝導率	W/m・K		Viscosity 粘度	mPa・s
	Fouling factor 汚れ係数	m ² ・K/W		Fouling factor of seal liquid 封液汚れ係数	m ² ・K/W
	Remarks 備考	Spare parts 予備品			



Tsurumi Production Network

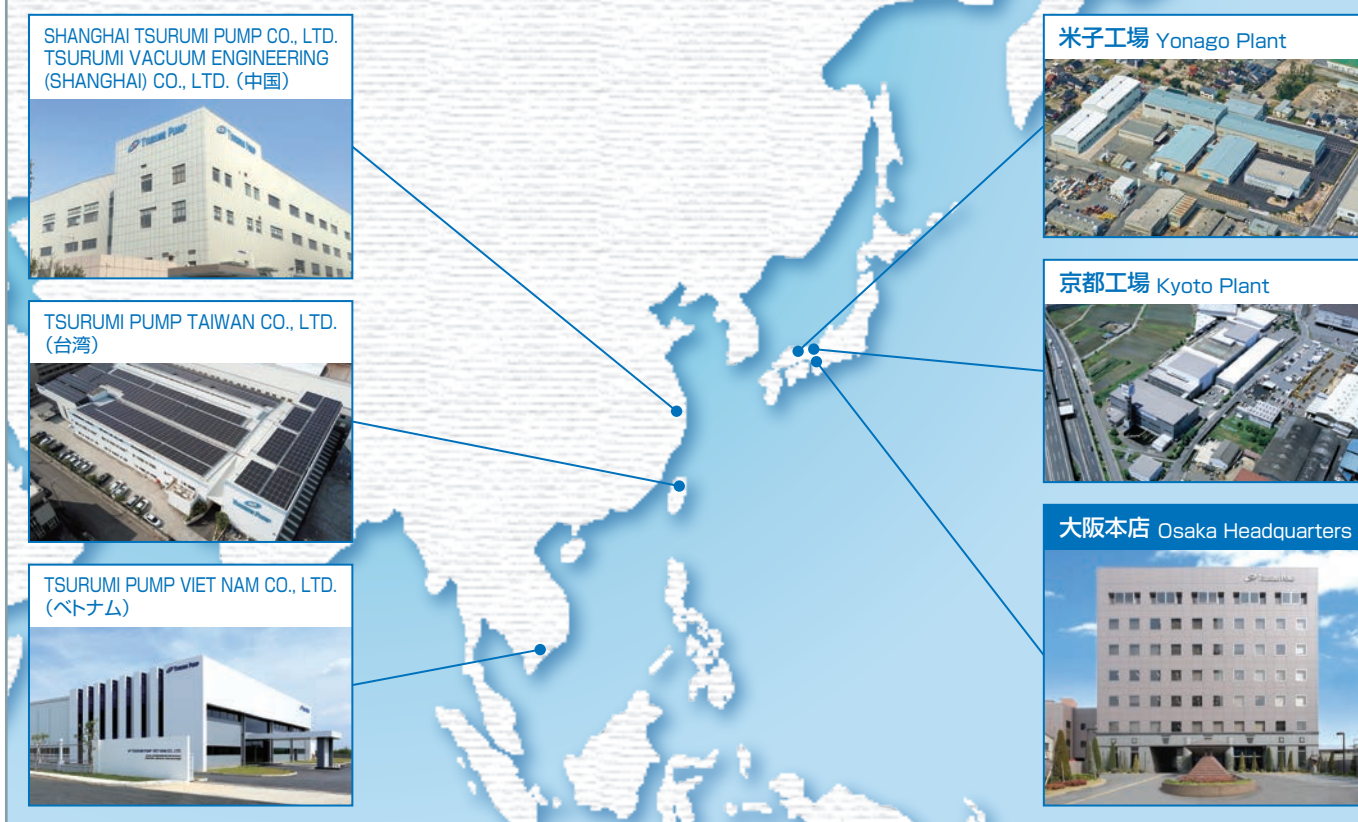

製品に関するご質問、カタログ請求などは、こちらまでお問い合わせください。

VP営業部

東京営業課 ☎(03)3833-0336 〒110-0016 東京都台東区台東1-33-8 ㊟(03)3835-1695

大阪営業課 ☎(06)6911-7111 〒538-8585 大阪市鶴見区鶴見4-16-40 ㊟(06)6911-2930 vpsales@tsurumipump.co.jp

ISO9001 Certified
 京都工場・米子工場・大阪本店ポンプシステム部・東京本社ポンプシステム部・各支店ポンプシステム課(北海道/東北/中部/中国/四国/九州)・新潟営業所・横浜営業所・大宮営業所・米子営業所

ISO14001 Certified
 大阪本店・東京本社・京都工場・北海道支店・東北支店・北関東支店・東京支店・中部支店・北陸支店・近畿支店・中国支店・四国支店・九州支店・新潟営業所・横浜営業所・大宮営業所・米子営業所

▲安全に関するご注意
 ご使用の前に取扱説明書をよくお読みの上、正しくお使いください。
 Be sure to thoroughly read and understand the operation manual before using the equipment in order to operate correctly.

*本カタログに示してある単位および数値は国際単位系(SI)によるものです。
 *本カタログに掲載されております写真ならびに仕様は、改良などによりお届けいたします商品と異なる場合がありますので、あらかじめご了承ください。
 *本カタログ内の「〇〇型」の表記は、当社の機種/型式記号です。

*The units and values shown in this catalog are based on the International System of Units.
 *Product images and specifications may differ from actual products due to improvements.
 *The OO series and model OO are indicated with our series/model codes in this catalog.

大阪本店 〒538-8585 大阪市鶴見区鶴見4-16-40	☎(06)6911-2351(代)	㊟(06)6911-1800
東京本社 〒110-0016 東京都台東区台東1-33-8	☎(03)3833-9765(代)	㊟(03)3835-8429
京都工場 〒614-8163 京都府八幡市上奈良長池1-1	☎(075)971-0831(代)	㊟(075)971-1316
米子工場 〒683-0851 鳥取県米子市夜見町2700	☎(0859)29-0811	㊟(0859)24-0602
北海道支店 〒065-0020 札幌市東区北20条東17-1-5	☎(011)787-8385	㊟(011)787-7216
東北支店 〒984-0042 仙台市若林区大和町4-9-11	☎(022)284-4107	㊟(022)236-2948
東京支店 〒110-0016 東京都台東区台東1-33-8	☎(03)3833-0331	㊟(03)3835-1621
北関東支店 〒370-0046 高崎市江木町1716-1	☎(027)310-1122	㊟(027)310-1212
北陸支店 〒920-0059 金沢市示野町西8	☎(076)268-2761	㊟(076)268-3461
中部支店 〒463-0853 名古屋市中村区牛田通2-19	☎(052)481-8181	㊟(052)482-1420
近畿支店 〒538-0054 大阪市鶴見区緑2-1-28	☎(06)6911-2311	㊟(06)6911-1119
中国支店 〒731-5132 広島市佐伯区吉見園1-21	☎(082)923-5171	㊟(082)923-0155
四国支店 〒761-8075 高松市多肥下町1554-28	☎(087)815-3535	㊟(087)815-3737
九州支店 〒812-0004 福岡市博多区榎田2-9-30	☎(092)452-5001	㊟(092)452-5013

OSAKA HEADQUARTERS
 16-40, 4-chome, Tsurumi, Tsurumi-ku, Osaka 538-8585, Japan
 Phone 81-6-6911-7111 Fax 81-6-6911-2930
 E-mail: vpsales@tsurumipump.co.jp

TOKYO HEAD OFFICE
 33-8, 1-chome, Taito, Taito-ku, Tokyo 110-0016, Japan
 Phone 81-3-3833-0336 Fax 81-3-3835-1695
 E-mail: vpsales@tsurumipump.co.jp

TSURUMI PUMP KOREA CO., LTD.
 Rm. 728, PoongLim Building, 127, Mapo-daero Seoul 04144, Korea
 Phone 82-2-701-6356 Fax 82-2-701-6358
 E-mail: tsurumipump@korea.com

TSURUMI VACUUM ENGINEERING (SHANGHAI) CO., LTD.
 1st Floor No. 3 Building, No. 386 Hangyi Road, Fengxian District, Shanghai 201499, China
 Phone 86-21-5724-2030 Fax 86-21-5724-5545
 E-mail: tsurumi@vip.sina.com

KYOTO PLANT
 1-1, Kaminaranagaikae, Yawata-city, Kyoto 614-8163, Japan
 Phone 81-75-971-0831 Fax 81-75-971-1316

YONAGO PLANT
 2700, Yomi-cho, Yonago-city, Tottori 683-0851, Japan
 Phone 81-859-29-0811 Fax 81-859-24-0602

株式会社 鶴見製作所
 www.tsurumipump.co.jp



Liquid Ring Vacuum Pumps **V・VL**
 液封式真空ポンプ

Liquid Ring Vacuum Pumps that Meet Industrial Field's Needs

LIGHT WEIGHT・COMPACT
 軽量・コンパクト

SUPERIOR DURABILITY
 優れた耐久性

HIGH EFFICIENCY・LOW NOISE
 高効率・低騒音

“One-rotation, One-action” remarkably improves operation in the high vacuum range.
The V/VL series provides high efficiency across the whole range, and ensures high reliability.

1回転1作動で高真空域を飛躍的に向上。全域で高効率を実現し信頼性の高いシリーズ。

Features of liquid ring vacuum pumps 液封式真空ポンプの特長

- Since the ring liquid prevents internal leaks, there is a wide clearance between the rotary parts and stationary parts.
封液が内部漏れを防止しますので、回転部と静止部分の隙間を大きく取る事ができます。
- The ring liquid serves as a piston. Therefore, pump performance is not affected by liquid drips in the suction gas.
封液がピストンの代わりをしますので、吸込気体に液滴が混入しても性能に影響がありません。
- The rotary pump can be designed to be compact. It can reduce vibrations, and does not generate pulsating flow on the discharge side.
回転式なので小形に設計でき、振動も小さく吐出し側においても脈動流を生じません。
- Ball valves are provided with “one-rotation, one-action” type, to ensure stable operation even in the high vacuum range.
1回転1作動形にボールバルブを装着しており、高真空域でも安定した運転を実現。
- Featuring low-noise and low-vibration characteristics.
低騒音・低振動の特性をもっています。

Major Applications 主な用途

- Vacuum Dewatering 真空脱水
- Vacuum Drying 真空乾燥
- Distillation, Concentration 蒸留・濃縮
- Cooling 冷却
- Priming 各種呼び水
- Vacuum Transportation, Vacuum-Chucking 真空輸送・吸着搬送
- Various Filters for the Chemical Industries 化学工業における各種フィルタ
- Paper Machines for Pulp and Paper Mills パルプ・製紙工業における抄紙機用
- Flue Gas Desulfurization for Steel Industries and Power Industries 製鉄業、電力業における排煙脱硫装置
- Other Various Vacuum Sources その他各種真空源として

High-performance pumps that play active roles in various industrial fields.



高性能なので多様な産業分野で活躍!!

Gas ejector attached example
 <ガスエゼクタ組合せ例>



● In the liquid ring pump, ring liquid vaporizes into the gas area between ring liquid and impeller blade.
 When ring liquid temperature will be higher, capacity of the pump will decrease because this vaporizing will also increase. Especially in the high vacuum conditions, the influence of ring liquid temperature is more significant.
 Then, when ring liquid is other than water, temperature factor of water also can be used, and refer the same temperature of vapor pressure with water. (15 °C ring water temperature is the standard performance basis, and temperature factor means the ratio from this standard temperature 15°C.)
 For details, refer to <Influence of ring water temperature> on p. 29 at the end of this catalog.

液封式ポンプでは、ポンプ内の空間部を封液蒸気が占めているため、封液温度が上昇し蒸気圧が高くなると吸込量が低下し、特に高真空域では影響が大きくなります。
 なお封液が水以外の場合には、同じ蒸気圧の水温の変化率を目安としてください。(ここで標準封水温度15℃に対する吸込量の比を変化率といいます。)
 詳細は巻末29ページ(封水温度の影響)をご覧ください。

A lightweight, compact type of <Monoblock type liquid ring vacuum pump “VD series”> is also available from our product lineup, in addition to the models described in this catalog.
 本カタログ掲載以外にも、軽量・コンパクトな(モータ一体型液封式真空ポンプ VD型)も取扱っています。

Operating Principle of Liquid Ring Vacuum Pump 液封式真空ポンプの作動原理

(Driving Situation for Visualized Demonstration Machine 可視化実演機による運転状況)

Stopped State 停止時

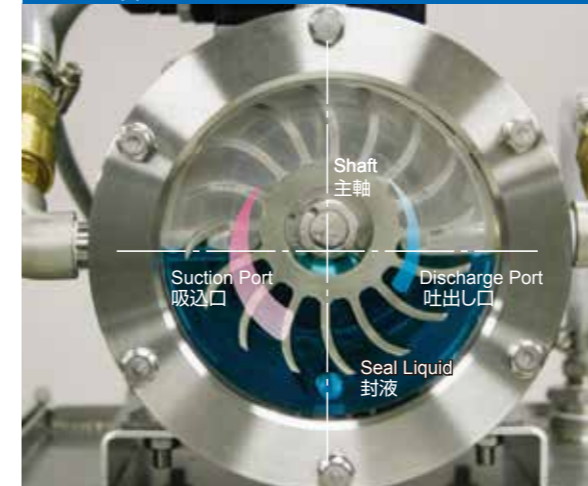

1 Rotation 回転

While the impeller rotates, seal liquid flows circulate along the inner wall of the casing under centrifugal force, to form a “liquid ring”. Because the impeller is eccentrically offset, the space generated by the rotation of the impeller is crescent-shaped, instead of a circle centered on the shaft.

羽根車が回転すると、封液は遠心力によりケーシング内壁に沿って還流し封液環を形成します。羽根車は、ケーシングの中心ではなく、ずれた位置(偏心)にあります。そのため、羽根車の回転によって生まれる空間は、主軸を中心とした円状ではなく三日月状となります。

2 Suction 吸込

The suction port is located in the position where the crescent-shaped space expands. The liquid sucked into the suction port is pushed into the space (gas cell) enclosed by the impeller blade and the “ring liquid”.

三日月状の空間が拡大する位置に吸込口があります。吸引された気体は羽根と封液環によってできた空間(気室)に閉じ込められます。

Operation Condition 回転時(運転時)

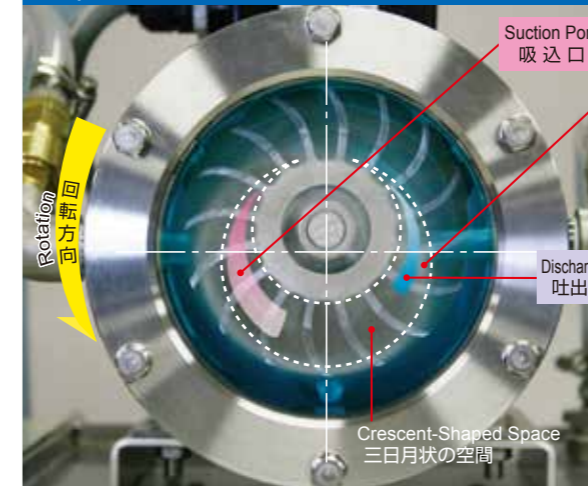

3 Compression 圧縮

As shown in the figure, the gas cell becomes smaller as the rotation continues. This means that the gas volume is being reduced, resulting in compression.

図でわかるように、気室は回転が進むにつれて小さくなります。つまり、気体の容積が小さくなり、圧縮されることを意味します。

4 Discharge 吐出し

Compressed air is discharged from the discharge port, which is located in the position where compressed gas pressure is increased to the specified level.

所要の圧力まで高まる位置に設けられた吐出し口から、圧縮された空気が排出されます。

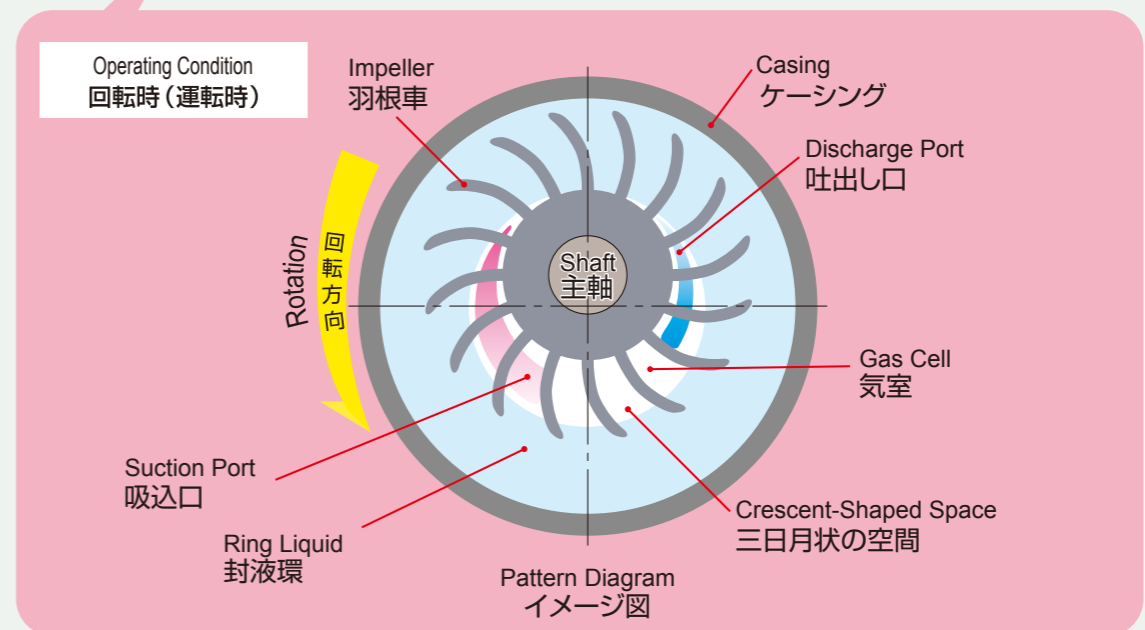

Features of Ball Valve ボールバルブについて

- Maintains a stable suction capacity even in the high vacuum condition.
高真空域でも安定した吸込量を維持
- Reduces running costs and power loss.
損失動力を軽減させ、運転コストを低減
- Reduces noise emissions.
騒音の低減化

Function of ball valve ボールバルブの機構

Ball valves are provided at the discharge port. It comprises the round holes in the port plate, balls (PTFE balls) and the ball holder. According to increase/decrease in operating pressure, the ball valve is activated to prevent excessive compression and reversed flow of gas.

吐出しポート部に設けられ、仕切板に開けた円孔とボール(テフロン球)、ボールの格納部からなり運転圧力の高低によって過圧縮や逆流圧縮を防止します。

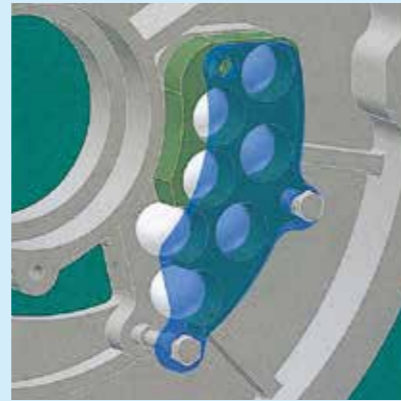

Ball Valve Functions ボールバルブの働き

Flow of gas
気体の流れ

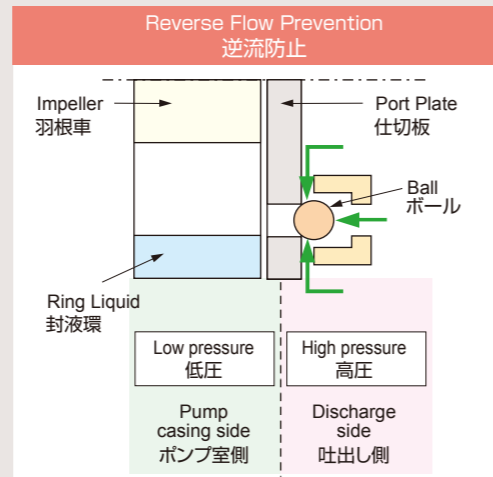
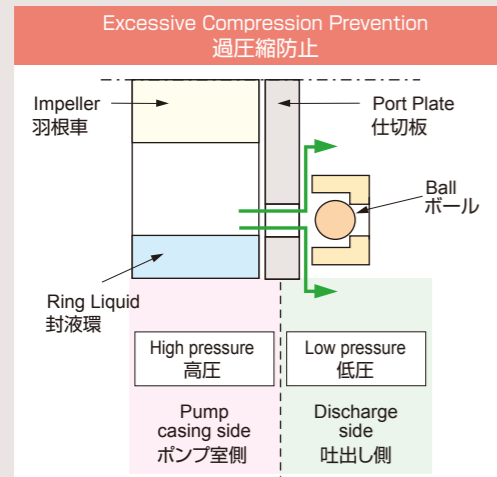

Performance comparison of variable port type and non-variable port type 可変ポート式と固定ポート式の性能比較

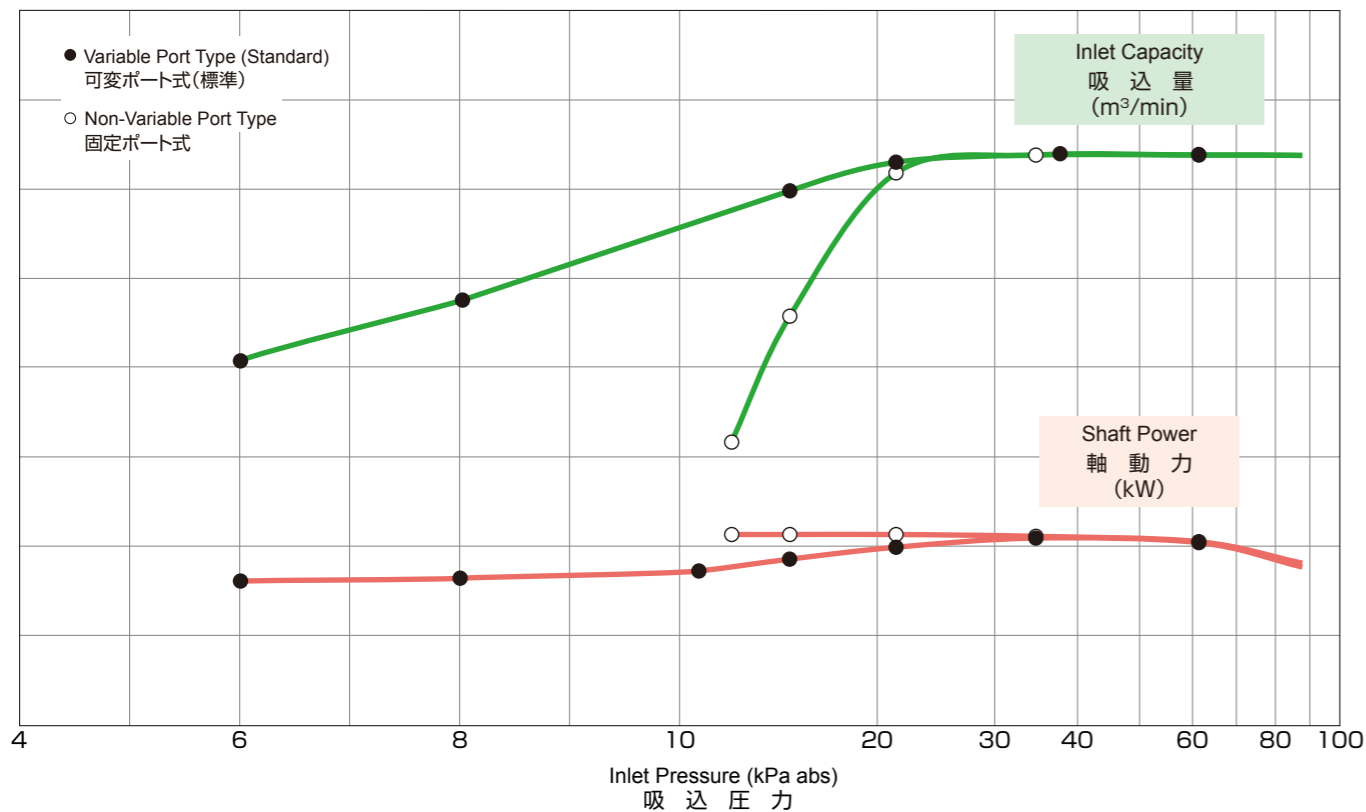

Liquid Ring Vacuum Pump 液封式真空ポンプ

V Model (V型)



Direct drive type
直結形



Belt drive type
ベルト掛形

Standard Specifications 標準仕様

Item 項目		Bore [Inlet x Outlet] 吸込×吐出し口径 (mm)	40x40	50x50	65x65	80x80	100x100	125x125	
Handled gas and seal liquid 取扱気体 封液	Seal liquid 封液名	Water 水	150x150	175x175	200x200	250x250			
	Seal liquid temperature 封液温度	13~50°C							
	Gas 取扱ガス	Air 空気							
	Gas temperature 取扱ガス温度	Normal temperature 常温							
	Outlet pressure 吐出し圧力	101.3 kPa abs (0 kPa G)							
	Pump ポンプ	Structure 構造	Seal liquid filling method 封液注入方式	Pressurized 圧入式					
Seal liquid required pressure 封液所要圧力			0.1 MPa G						
Outlet type 吐出し口方式			Variable port (Ball valve) 可変ポート式(ボールバルブ)						
Shaft seal 軸封			Gland packing グランドパッキン式						
Material 材質		Casing ケーシング	FC200						
		Port plate 仕切板	FC250						
		Impeller 羽根車	FC250						
		Shaft 主軸	SUS420J2						
		Motor モータ	Type / Pole 形式 / 極数	IE3, TEFC (indoor), /4-6-8-10-12-14-pole IE3仕様, 全閉外扇屋内形 /4-6-8-10-12-14極					
			Phase / Voltage 相 / 電圧	50Hz: 3-phase (三相) 200V 60Hz: 3-phase (三相) 200 & 220V					
Piping connection 配管との接続	JIS10K (RF)								
Paint color 塗装色	Pump ポンプ部: 10B3/8 Coupling cover 安全カバー: 2.5Y8/12								

Model Description 型式説明

Model of the following is the description for model example:
下記の型式は説明用型式例です。

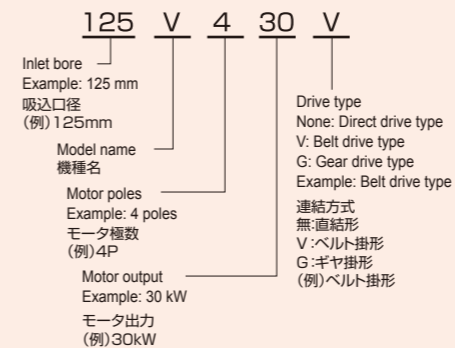

Standard Accessories (Direct Drive Type) 標準付属品(直結形)

- Common base 1 pc (1個)
- Foundation bolt 1 set (1式)
- Motor 1 pc (1台)
- Coupling 1 set (1式)
- Coupling cover 1 set (1式)
- Seal liquid control valve 1 pc (1個)

Special Accessories 特別付属品

- Vacuum gauge with cock 真空計及びコック
- Separator tank セパレータータンク
- Temporary strainer テンポラリストレーナ
- Gas check valve ガス入口逆止弁
- Seal liquid flow meter 封液流量計
- Special tool 特殊分解工具
- Gas ejector ガスエ젝タ

40V~
250V

Inlet Capacity
吸込量
(m³/min)

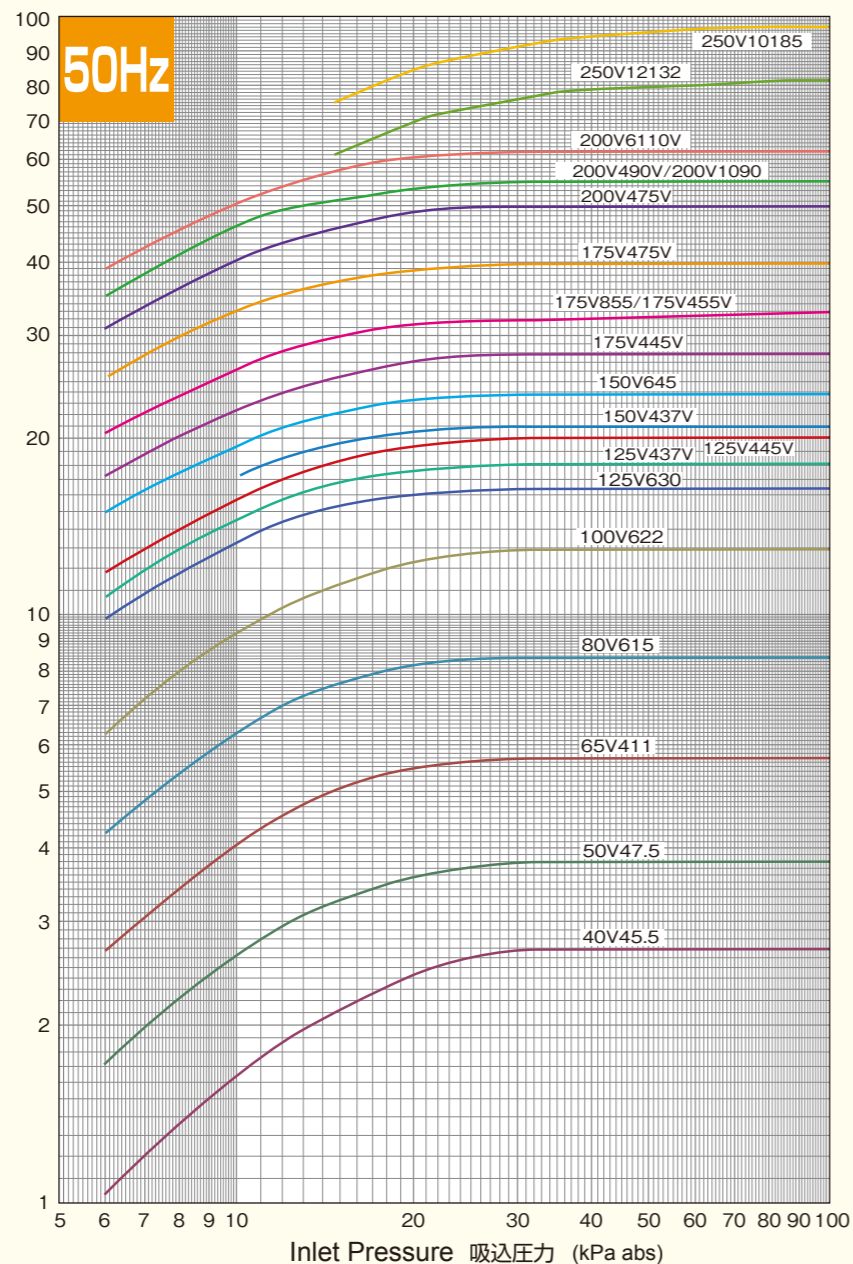

40V~
250V

Inlet Capacity
吸込量
(m³/min)

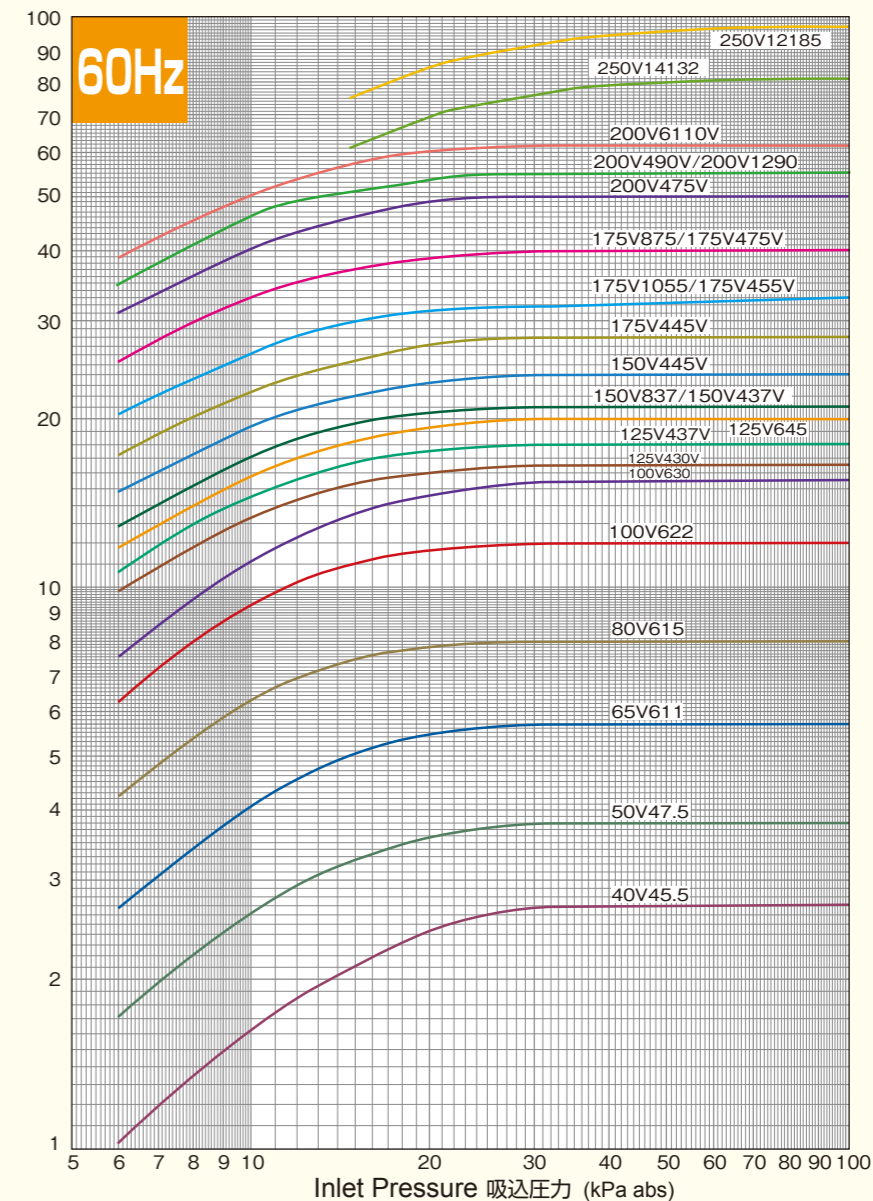

50 Hz Standard Specifications (at a seal liquid temperature of 15°C) 50Hz 標準仕様 (封水温度15°Cの場合)

Bore [Inlet × Outlet] 口径 吸込×吐出 (mm)	Model 型式	Pump model ポンプ部 型式	Drive type 連結方式	Pump speed 回転速度 (min ⁻¹)	Motor output 出力 (kW)	Pole 極数 (P)	Inlet capacity [Inlet condition] 吸込量(吸込状態) (m ³ /min)						Approx. seal liquid flow rate 概略封水量 (ℓ/min)
							Inlet pressure 吸込圧力 (kPa G)						
							-93.3	-90.6	-86.6	-80.0	-66.6	0	
							8.0	10.7	14.7	21.3	34.7	101.3	14.7
40×40	40V45.5	40EV254	Direct drive type	1450	5.5	4	1.35	1.72	2.1	2.5	2.7	2.7	20
50×50	50V47.5	50EV256	Direct drive type	1450	7.5	4	2.22	2.75	3.25	3.64	3.8	3.8	25
65×65	65V411	65EV258	Direct drive type	1450	11	4	3.44	4.26	5.02	5.55	5.7	5.7	30
80×80	80V615	80EV354	Direct drive type	970	15	6	5.4	6.6	7.6	8.3	8.5	8.5	35
100×100	100V622	100EV356	Direct drive type	970	22	6	8	9.7	11.3	12.5	13	13	50
125×125	125V630	125EV358	Direct drive type	970	30	6	11.8	13.8	15.3	16.2	16.5	16.5	60
125×125	125V437V	125EV358	Belt drive type	1070	37	4	13	15	16.7	17.7	18	18	70
125×125	125V445V	125EV358	Belt drive type	1150	45	4	14	16.3	18.2	19.5	20	20	70
150×150	150V437V	150EV466	Belt drive type	870	37	4	15.3	17.7	19.6	20.7	21	21	70
150×150	150V645	150EV466	Direct drive type	970	45	6	17.3	20	22	23.5	24	24	70
175×175	175V445V	175EV456	Belt drive type	650	45	4	20.1	23.1	25.5	27.5	28	28	70
175×175	175V855	175EV456	Direct drive type	730	55	8	23.8	27.2	30	31.6	32	33	100
175×175	175V455V	175EV456	Belt drive type	730	55	4	23.8	27.2	30	31.6	32	33	100
175×175	175V475V	175EV456	Belt drive type	870	75	4	30	34.1	37.2	39.3	40	40	100
200×200	200V475V	200EV	Belt drive type	530	75	4	36.2	41.7	46	49.2	50	50	130
200×200	200V1090	200EV	Direct drive type	590	90	10	41	47.5	51	54	55	55	130
200×200	200V490V	200EV	Belt drive type	590	90	4	41	47.5	51	54	55	55	130
200×200	200V6110V	200EV	Belt drive type	670	110	6	45.5	52	57.5	61	62	62	150
250×250	250V12132	250EVF	Direct drive type	495	132	12	-	-	61	71	78	81	260
250×250	250V10185	250EVF	Direct drive type	590	185	10	-	-	75	86	93	97	260

* The seal liquid flow rate indicates the values at -86.6 kPa G (14.7 kPa abs). *印封水量は-86.6kPa G(14.7kPa abs)時の値です。

60 Hz Standard Specifications (at a seal liquid temperature of 15°C) 60Hz 標準仕様 (封水温度15°Cの場合)

Bore [Inlet × Outlet] 口径 吸込×吐出 (mm)	Model 型式	Pump model ポンプ部 型式	Drive type 連結方式	Pump speed 回転速度 (min ⁻¹)	Motor output 出力 (kW)	Pole 極数 (P)	Inlet capacity [Inlet condition] 吸込量(吸込状態) (m ³ /min)						Approx. seal liquid flow rate 概略封水量 (ℓ/min)
							Inlet pressure 吸込圧力 (kPa G)						
							-93.3	-90.6	-86.6	-80.0	-66.6	0	
							8.0	10.7	14.7	21.3	34.7	101.3	14.7
40×40	40V45.5	40EV264	Direct drive type	1750	5.5	4	1.35	1.72	2.1	2.5	2.7	2.7	20
50×50	50V47.5	50EV266	Direct drive type	1750	7.5	4	2.22	2.75	3.25	3.64	3.8	3.8	25
65×65	65V611	65EV362	Direct drive type	1150	11	6	3.44	4.26	5.02	5.55	5.7	5.7	30
80×80	80V615	80EV364	Direct drive type	1150	15	6	5.4	6.55	7.4	7.9	8	8	35
100×100	100V622	100EV366	Direct drive type	1150	22	6	8	9.7	11	11.8	12	12	50
100×100	100V630	100EV356	Direct drive type	1150	30	6	9.5	11.6	13.5	14.8	15.5	15.5	60
125×125	125V430V	125EV358	Belt drive type	970	30	4	11.8	13.8	15.3	16.2	16.5	16.5	60
125×125	125V437V	125EV358	Belt drive type	1070	37	4	13	15	16.7	17.7	18	18	70
125×125	125V645	125EV358	Direct drive type	1150	45	6	14	16.3	18.2	19.5	20	20	70
150×150	150V837	150EV466	Direct drive type	870	37	8	15.3	17.7	19.6	20.7	21	21	70
150×150	150V437V	150EV466	Belt drive type	870	37	4	15.3	17.7	19.6	20.7	21	21	70
150×150	150V445V	150EV466	Belt drive type	970	45	4	17.3	20	22	23.5	24	24	70
175×175	175V445V	175EV456	Belt drive type	650	45	4	20.1	23.1	25.5	27.5	28	28	70
175×175	175V1055	175EV456	Direct drive type	710	55	10	23.8	27.2	30	31.6	32	33	100
175×175	175V455V	175EV456	Belt drive type	710	55	4	23.8	27.2	30	31.6	32	33	100
175×175	175V875	175EV456	Direct drive type	870	75	8	30	34.1	37.2	39.3	40	40	100
175×175	175V475V	175EV456	Belt drive type	870	75	4	30	34.1	37.2	39.3	40	40	100
200×200	200V475V	200EV	Belt drive type	530	75	4	36.2	41.7	46	49.2	50	50	130
200×200	200V1290	200EV	Direct drive type	590	90	12	41	47.5	51	54	55	55	130
200×200	200V490V	200EV	Belt drive type	590	90	4	41	47.5	51	54	55	55	130
200×200	200V6110V	200EV	Belt drive type	670	110	6	45.5	52	57.5	61	62	62	150
250×250	250V14132	250EVF	Direct drive type	505	132	14	-	-	61	71	78	81	260
250×250	250V12185	250EVF	Direct drive type	590	185	12	-	-	75	86	93	97	260

* The seal liquid flow rate indicates the values at -86.6 kPa G (14.7 kPa abs). *印封水量は-86.6kPa G(14.7kPa abs)時の値です。

Dimension Drawing (Direct drive type / 40-150 V) Unit: mm
外形寸法図(直結形) 単位:mm 40V型~150V型

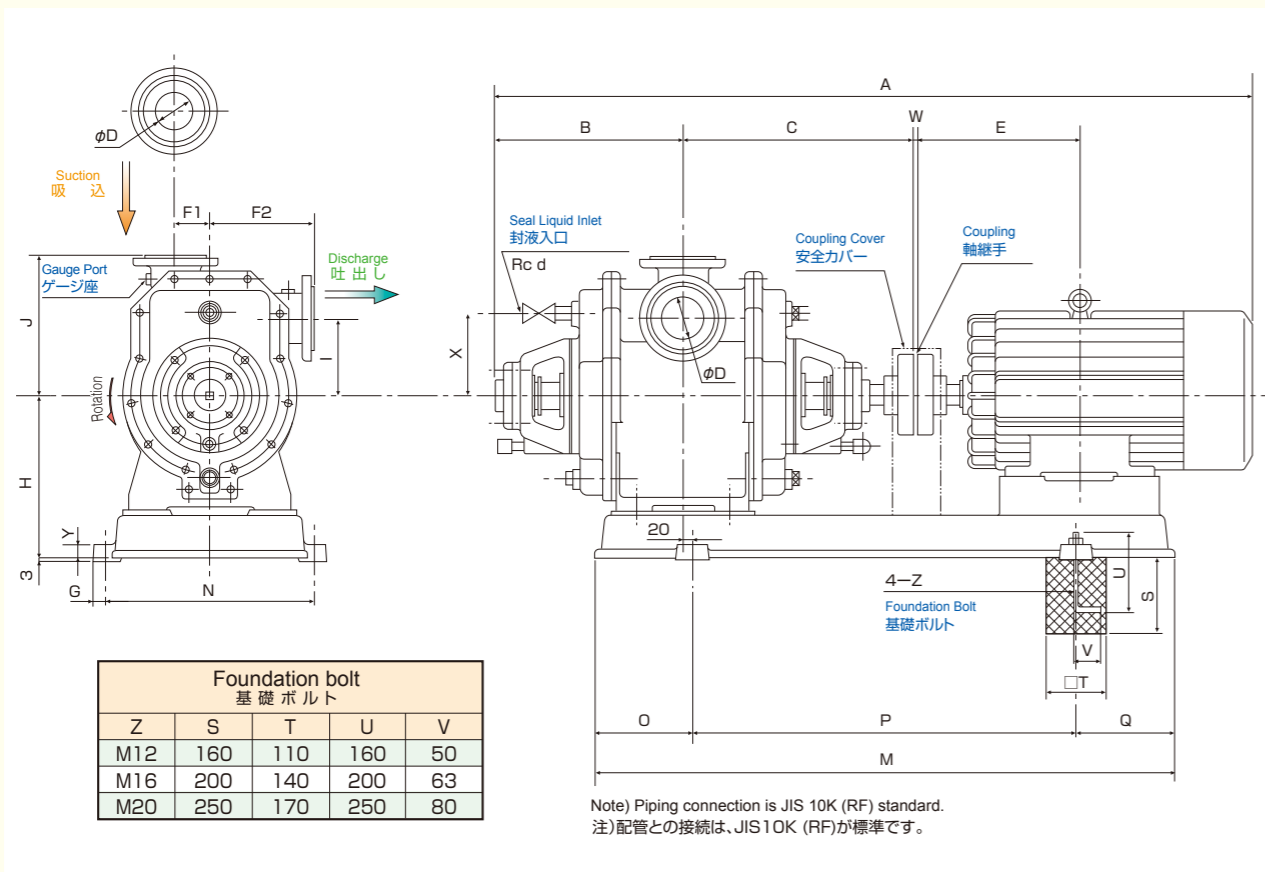

50 Hz Dimensions (Direct drive type) Unit: mm 50Hz 寸法表(直結形) 単位:mm

Model 型式	D	A	B	C	E	F1	F2	G	H	I	J	M	N	O-Q	P	W	X	Y	Z	d*	Approx. mass 概略質量 (kg)
40V45.5	40	1103.5	299	374	239	50	190	21	275	135	250	880	340	120	640	3	145	25	M12	3/4	235
50V47.5	50	1185.5	321	396	258	50	190	21	275	135	250	910	340	130	650	3	145	25	M12	3/4	260
65V411	65	1353	356	431	323	50	190	21	275	135	250	1060	400	160	740	3	145	25	M12	3/4	305
80V615	80	1612	417	527	351.5	70	250	25	375	190	330	1250	490	180	890	3	200	30	M16	1	610
100V622	100	1806	477	587	370.5	70	250	25	375	190	330	1440	500	240	960	4	200	30	M16	1	760
125V630	125	2056	548	660	425.5	75	270	30	420	190	350	1710	630	260	1190	4	205	40	M20	1½	1060
150V645	150	2028	530	643	432	100	295	30	450	235	400	1800	680	300	1200	4	250	50	M20	1½	1230

60 Hz Dimensions (Direct drive type) Unit: mm 60Hz 寸法表(直結形) 単位:mm

Model 型式	D	A	B	C	E	F1	F2	G	H	I	J	M	N	O-Q	P	W	X	Y	Z	d*	Approx. mass 概略質量 (kg)
40V45.5	40	1127.5	311	386	239	40	180	21	250	120	230	850	340	120	610	3	135	25	M12	1/2	225
50V47.5	50	1213.5	335	410	258	40	180	21	250	120	230	930	340	140	650	3	135	25	M12	1/2	240
65V611	65	1455	381	476	345	55	220	25	325	145	280	1140	430	160	820	3	170	30	M16	3/4	440
80V615	80	1589	413	508	351.5	55	220	25	325	145	280	1240	440	180	880	3	170	30	M16	3/4	540
100V622	100	1735	449	544	370.5	70	230	25	340	170	310	1400	490	240	920	4	190	30	M16	1	670
100V630	100	1912	477	587	425.5	70	250	25	375	190	330	1440	500	240	960	4	200	30	M16	1	890
125V645	125	2063	548	660	432	75	270	30	420	190	350	1710	630	260	1190	4	205	40	M20	1½	1240
150V837	150	2116	530	643	463.5	100	295	30	450	235	400	1800	680	300	1200	4	250	50	M20	1½	1220

The approximate mass includes the standard common base and motor.
Dimension may change in accordance with revisions and improvements. Please request detailed drawing if use for actual design purposes.
概略質量は標準仕様の共通ベース、モータを含みます。
改良により、寸法は変更となることがあります。設計用としてご使用の場合は、別途納入図を請求ください。

* The "d" dimensions are indicated in inches.
*印d寸法につきましては、表示単位はinchとなります。

Dimension Drawing (Direct drive type / 175-200 V) Unit: mm
外形寸法図(直結形) 単位:mm 175V型・200V型

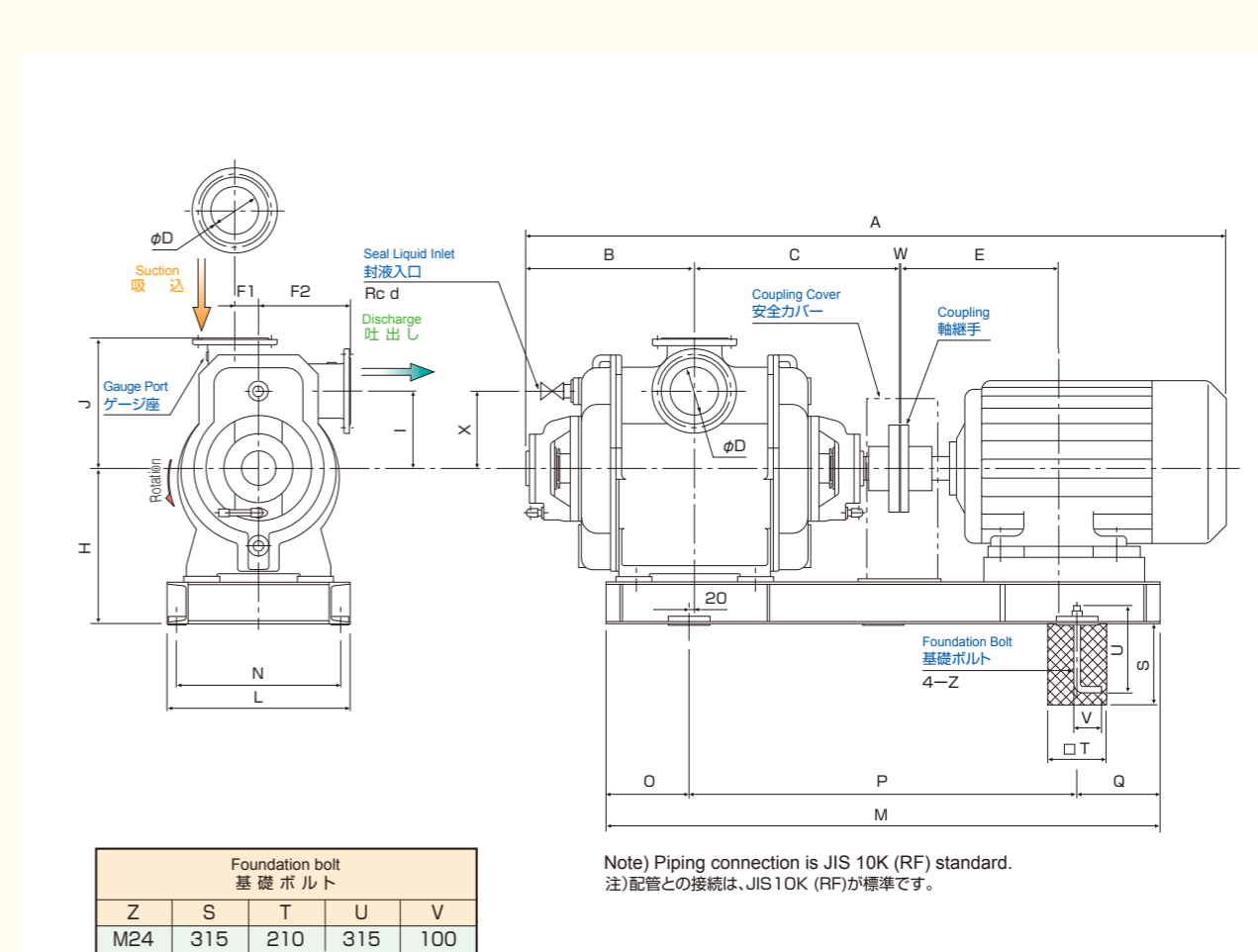

50 Hz Dimensions(Direct drive type) Unit: mm 50Hz 寸法表(直結形) 単位:mm

Model 型式	D	A	B	C	E	F1	F2	H	I	J	L	M	N	O-Q	P	W	X	Z	d*	Approx. mass 概略質量 (kg)
175V855	175	2422	610	740	544	85	330	560	280	470	590	1850	520	275	1300	4	280	M24	1½	1800
200V1090	200	3064	738	904	588.5	100	390	670	350	560	700	2200	630	350	1500	5	360	M24	2	3400
250V12132	Please contact the nearest our VP sales division because it is the design of the products on a case-by-case basis. 都度設計の製品ですので、最寄りの弊社VP営業部までお問い合わせください。																			
250V10185																				

60 Hz Dimensions(Direct drive type) Unit: mm 60Hz 寸法表(直結形) 単位:mm

Model 型式	D	A	B	C	E	F1	F2	H	I	J	L	M	N	O-Q	P	W	X	Z	d*	Approx. mass 概略質量 (kg)
175V875	175	2422	610	740	569.5	85	330	560	280	470	590	1880	520	275	1330	4	280	M24	1½	1900
200V1290	200	3269	738	904	741	100	390	670	350	560	700	2480	630	350	1780	5	360	M24	2	3400
250V14132	Please contact the nearest our VP sales division because it is the design of the products on a case-by-case basis. 都度設計の製品ですので、最寄りの弊社VP営業部までお問い合わせください。																			
250V12185																				

The approximate mass includes the standard common base and motor.
Dimension may change in accordance with revisions and improvements. Please request detailed drawing if use for actual design purposes.
概略質量は標準仕様の共通ベース、モータを含みます。
改良により、寸法は変更となることがあります。設計用としてご使用の場合は、別途納入図を請求ください。

* The "d" dimensions are indicated in inches.
*印d寸法につきましては、表示単位はinchとなります。

Dimension Drawing (Belt drive type / 125-250 V) Unit: mm
外形寸法図(ベルト掛形) 単位:mm 125V型~250V型

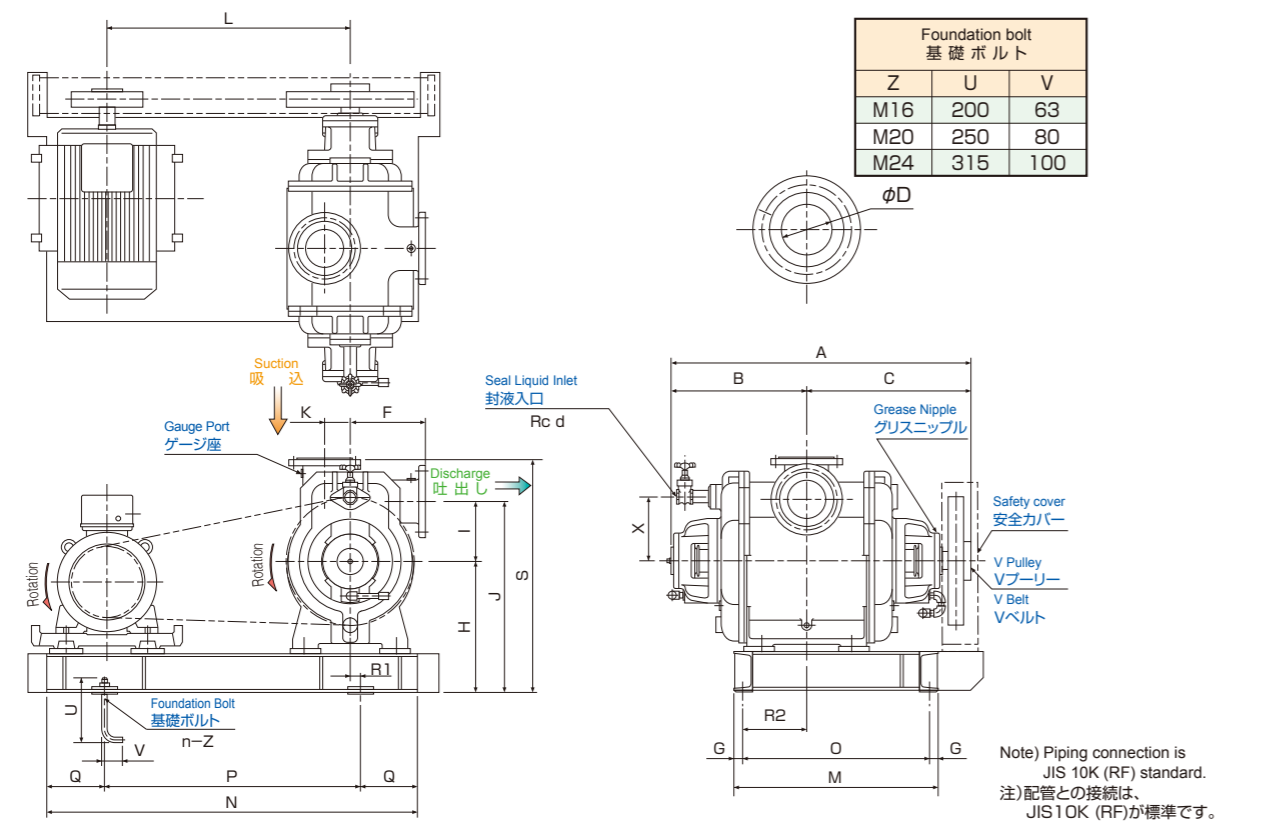

50 Hz Dimensions(Belt drive type) Unit: mm 50Hz 寸法表(ベルト掛形) 単位:mm

Model 型式	φD	A	B	C	F	G	H	I	J	K	L	M	N	O	P	Q	R1	R2	S	X	d*	n	Z	Approx. mass 概略質量 (kg)
125V437V	125	1208	548	660	270	35	480	190	670	75	900	800	1400	730	1000	200	50	220	830	205	1½	4	M20	830
125V445V	125	1208	548	660	270	35	480	190	670	75	900	800	1400	730	1000	200	50	220	830	205	1½	4	M20	860
150V437V	150	1173	530	643	295	35	510	235	745	100	950	800	1450	730	1000	225	40	250	910	250	1½	4	M20	1000
175V445V	175	1350	610	740	330	35	560	280	840	85	1100	900	1700	830	1200	250	50	290	1030	280	1½	4	M24	1300
175V455V	175	1350	610	740	330	35	560	280	840	85	1100	900	1700	830	1200	250	50	290	1030	280	1½	4	M24	1350
175V475V	175	1350	610	740	330	35	560	280	840	85	1100	900	1700	830	1200	250	50	290	1030	280	1½	4	M24	1550
200V475V	200	1642	738	904	390	35	670	350	1020	100	1300	1100	2000	1030	750x2	250	130	370	1230	360	2	6	M24	2300
200V490V	200	1642	738	904	390	35	670	350	1020	100	1300	1100	2000	1030	750x2	250	130	370	1230	360	2	6	M24	2350
200V6110V	200	1642	738	904	390	35	670	350	1020	100	1300	1100	2000	1030	750x2	250	130	370	1230	360	2	6	M24	2550

60 Hz Dimensions(Belt drive type) Unit: mm 60Hz 寸法表(ベルト掛形) 単位:mm

Model 型式	φD	A	B	C	F	G	H	I	J	K	L	M	N	O	P	Q	R1	R2	S	X	d*	n	Z	Approx. mass 概略質量 (kg)
125V430V	125	1208	548	660	270	35	480	190	670	75	900	800	1400	730	1000	200	50	220	830	205	1½	4	M20	770
125V437V	125	1208	548	660	270	35	480	190	670	75	900	800	1400	730	1000	200	50	220	830	205	1½	4	M20	830
150V437V	150	1173	530	643	295	35	510	235	745	100	950	800	1450	730	1000	225	40	250	910	250	1½	4	M20	1000
150V445V	150	1173	530	643	295	35	510	235	745	100	950	800	1450	730	1000	225	40	250	910	250	1½	4	M20	1050
175V445V	175	1350	610	740	330	35	560	280	840	85	1100	900	1700	830	1200	250	50	290	1030	280	1½	4	M24	1300
175V455V	175	1350	610	740	330	35	560	280	840	85	1100	900	1700	830	1200	250	50	290	1030	280	1½	4	M24	1350
175V475V	175	1350	610	740	330	35	560	280	840	85	1100	900	1700	830	1200	250	50	290	1030	280	1½	4	M24	1550
200V475V	200	1642	738	904	390	35	670	350	1020	100	1300	1100	2000	1030	750x2	250	130	370	1230	360	2	6	M24	2300
200V490V	200	1642	738	904	390	35	670	350	1020	100	1300	1100	2000	1030	750x2	250	130	370	1230	360	2	6	M24	2350
200V6110V	200	1642	738	904	390	35	670	350	1020	100	1300	1100	2000	1030	750x2	250	130	370	1230	360	2	6	M24	2550

The approximate mass includes the standard common base, pulley and motor.
Dimension may change in accordance with revisions and improvements. Please request detailed drawing if use for actual design purposes.
概略質量は標準仕様の共通ベース、プーリー、モータを含みます。
改良により、寸法は変更となることがあります。設計用としてご使用の場合は、別途納入図を請求ください。

* The "d" dimensions are indicated in inches.
*印d寸法につきましては、表示単位はinchとなります。

Sectional Drawing (40-250 V)
構造断面図(例) 40V型~250V型

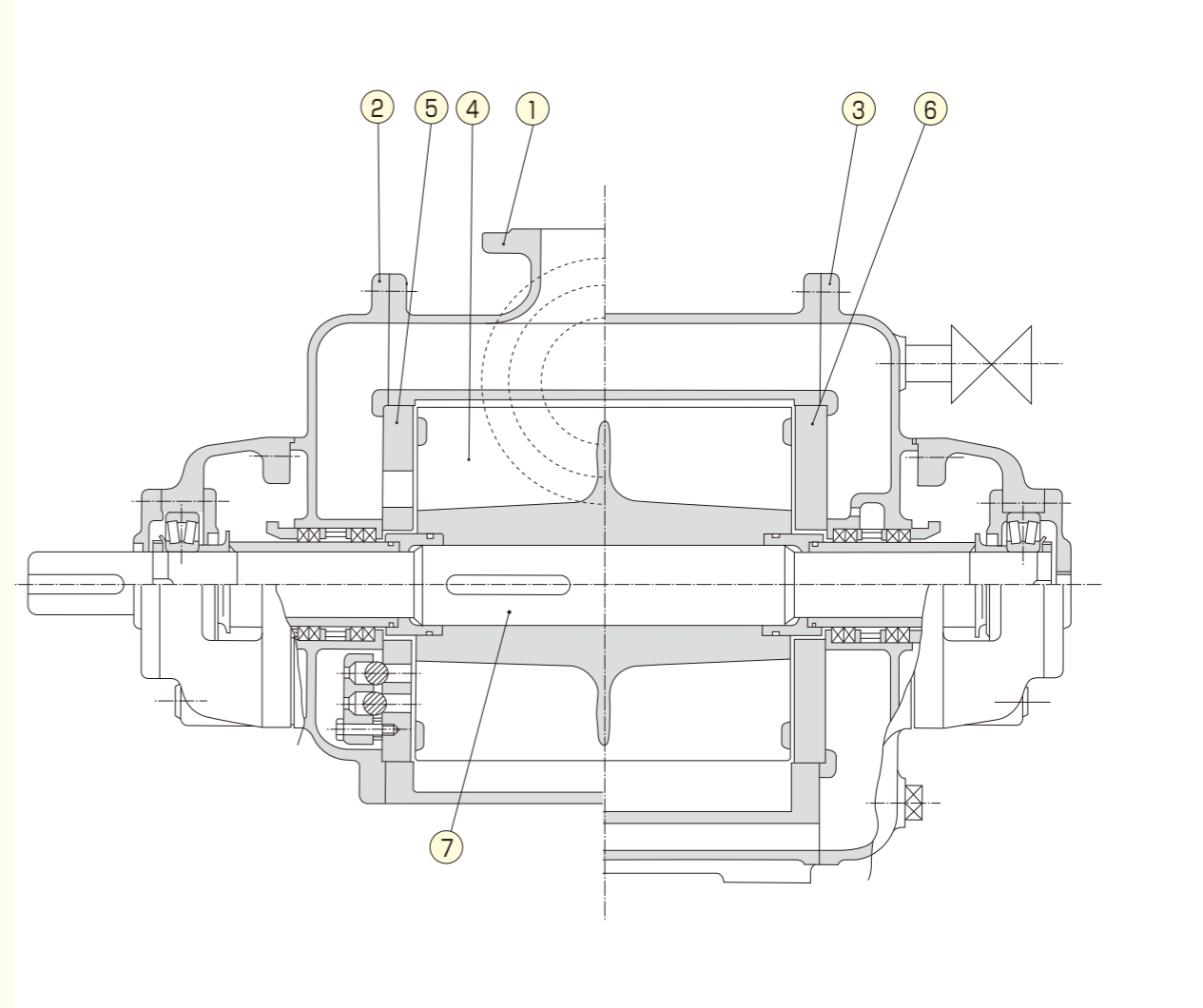

Part Description/Material List 品名・材質表

No. 品番	Part description 部品名称	Material 材質
1	Casing ケーシング	FC200
2	Side Cover (coupling side) サイドカバー(駆動側)	FC200
3	Side Cover (end side) サイドカバー(反駆動側)	FC200
4	Impeller 羽根車	FC250
5	Port Plate (coupling side) 仕切板(駆動側)	FC250
6	Port Plate (end side) 仕切板(反駆動側)	FC250
7	Shaft 主軸(シャフト)	SUS420J2

Liquid Ring Vacuum Pump

液封式真空ポンプ

VL



Standard Specifications 標準仕様

Item 項目	Bore [Inlet x Outlet] 吸込×吐出口径 (mm)			
	150×150	250×250	300×300	400×400
Handled gas and seal liquid 取扱気体・封液	Seal liquid 封液名	Water 水		
	Seal liquid temperature 封液温度	13~50°C		
	Gas 取扱ガス	Air 空気		
	Gas temperature 取扱ガス温度	Normal temperature 常温		
	Outlet pressure 吐出し圧力	101.3 kPa abs (0 kPa G)		
Pump ポンプ	Structure 構造	Seal liquid filling method 封液注入方式	Pressurized 圧入式	
		Seal liquid required pressure 封液所要圧力	0.1 MPa G	
		Outlet type 吐出し口方式	Variable port (Ball valve) 可変ポート式(ボールバルブ)	
		Shaft seal 軸封	Gland packing グランドパッキング式	
	Material 材質	Bearing 軸受	Self-aligning roller bearing, Thrust ball bearing 自動調心ころ軸受、スラスト軸受	
		Casing ケーシング	SS400	
		Port plate 仕切板	FC250	
		Impeller 羽根車	SS400	
Shaft 主軸	SUS420J2			
Motor モータ	Type 形式	IE3, TEFC (indoor) IE3仕様、全閉外扇屋内形		
	Phase / Voltage 相 / 電圧	50Hz: 3-phase (三相) 200V 60Hz: 3-phase (三相) 200 & 220V		
Piping connection 配管との接続		JIS10K (FF)		
Paint color 塗装色		Pump ボンプ部: 10B3/8 Safety cover 安全カバー: 2.5Y8/12		

VL type has a large capacity with high efficiency,
 • Paper Machines for Paper Mills
 • Condenser Gas Extraction System for Geothermal Power Plant
 • Various Filters for the Chemical Industries
 It is a Liquid Ring Vacuum Pump that can be used in various applications.
 Please contact our VP sales division because it selected the VL type according to the application.

VL型は大容量で高効率タイプであり、
 ・製紙工業における抄紙機用
 ・地熱発電所におけるガス抽出装置用
 ・化学工業における各種フィルター用
 などの各用途でご使用頂ける液封式真空ポンプです。
 ご用途に合ったVL型を選定致しますので、最寄りの弊社VP営業部までお問合せ下さい。

Special Specifications 特殊仕様

Pump ポンプ	Structure 構造	Shaft seal 軸封	Mechanical seal メカニカルシール式
	Material 材質	Casing ケーシング	SUS304, SUS316
Port plate 仕切板		SCS13, SCS14	
Impeller 羽根車		SUS304, SUS316	
Shaft 主軸		SUS304, SUS316	
Motor モータ	Type 形式	IE3, TEFC (outdoor) IE3仕様、全閉外扇屋外形 Increased safety Flameproof Enclosure 安全増防爆形、耐圧防爆形	
	Phase / Voltage 相 / 電圧	50Hz: 3-phase (三相) 400V 60Hz: 3-phase (三相) 400 & 440V	
	Piping connection 配管との接続	ASME 150lb(RF)	
Other その他	Change of paint color Witness examination Photography	塗装色変更 立会検査 写真撮影	

Please contact the nearest our VP sales division if in case of custom specifications other than above.
 ※上記以外の特殊仕様につきましては最寄りの弊社VP営業部まで、お問い合わせください。

Model Description 型式説明

Model of the following is the description for model example.
 下記の型式は説明用型式例です。

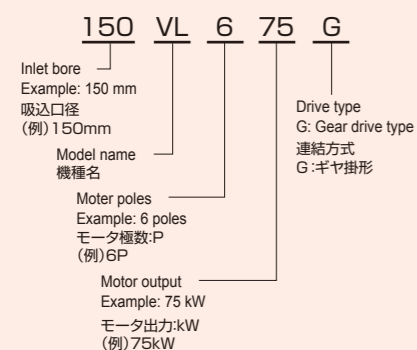

Standard Accessories (Gear Drive Type) 標準付属品 (ギヤ掛形)

- Common base 1 pc
共通ベース (1個)
- Foundation bolt 1 set
基礎ボルト (1式)
- Motor 1 pc
モータ (1台)
- Gear Reducer 1 set
減速機 (1式)
- Coupling 2 sets
軸継手 (2式)
- Coupling cover 1 set
安全カバー (1式)

Special Accessories 特別付属品

- Vacuum gauge with cock
真空計及びコック
- Connecting pipe (Inlet, Outlet)
ガス吸込、吐出し連結管
- Separator tank
セパレータータンク
- Temporary strainer
テンポラリストレーナ
- Gas check valve
ガス入口逆止弁
- Seal liquid flow meter
封液流量計
- Special tool
特殊分解工具

Performance Range 選定領域

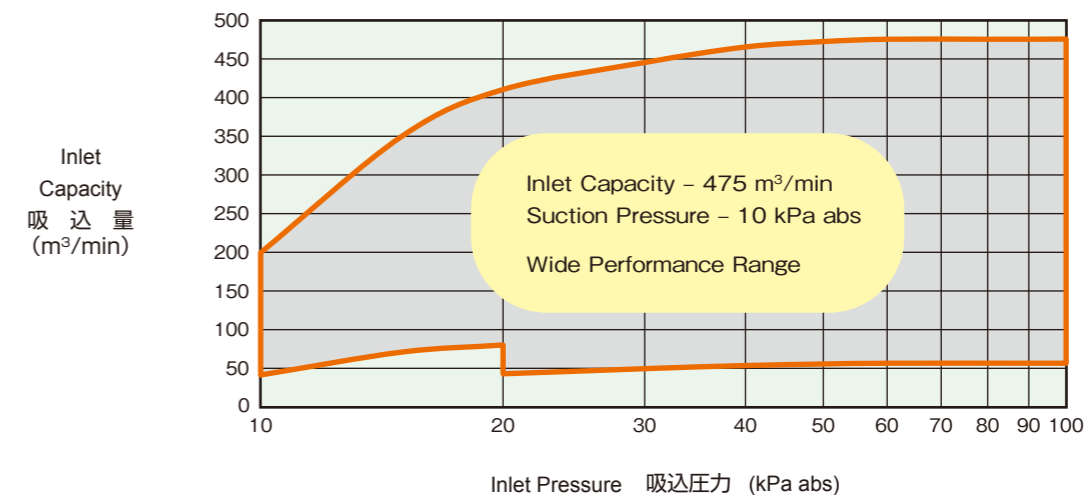

Sectional Drawing (150-400VL) 構造断面図 (例) 150VL型~400VL型

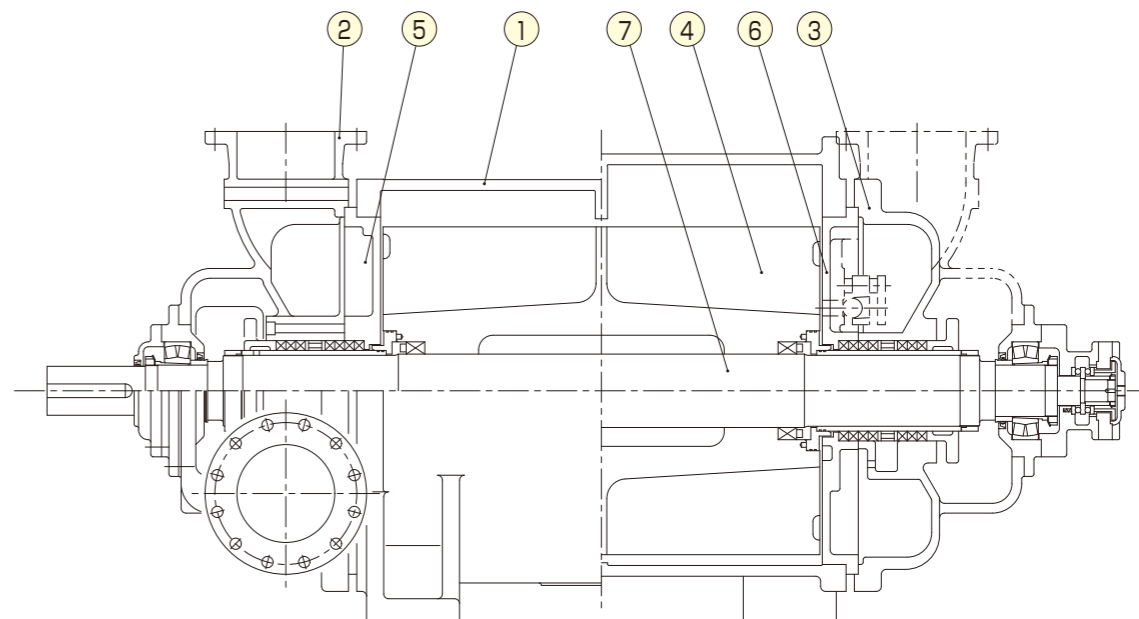

Part Discription/Material List 品名・材質表

No. 品番	Part discription 部品名称	Material 材質
1	Casing ケーシング	SS400
2	Side Cover (coupling side) サイドカバー (駆動側)	FC200
3	Side Cover (end side) サイドカバー (反駆動側)	FC200
4	Impeller 羽根車	SS400
5	Port Plate (coupling side) 仕切板 (駆動側)	FC250
6	Port Plate (end side) 仕切板 (反駆動側)	FC250
7	Shaft 主軸 (シャフト)	SUS420J2

Liquid ring vacuum pumps are provided with an operating mechanism that simultaneously discharges gas and seal liquid from the pump outlet. Thus, a separator tank is normally provided on the pump discharge side in order to separate the gas and liquid.

液封式真空ポンプはその作動機構上、吐出し口より気体と封液が同時に排出されますので、ポンプの吐出し側には通常気液分離のためにセパレータタンクを設置します。

Separator Tank(DTS type) for V
V型用 セパレータタンク

DTS型



Foundation bolt 基礎ボルト					
Z	S	T	U	V	
M12	160	110	160	50	
M16	200	140	200	63	
M20	250	170	250	80	
M24	315	210	315	100	

- Notes:
- Piping connection is JIS 10K(FF) standard.
 - Piping from outlet of the vacuum pump to separator tank should be horizontally or downward.
 - Piping of seal liquid should be exist as a length of less than 5m. Moreover, outlet of the pipe should be exposed to atmosphere.

- 注)
- 配管との接続は、JIS10K (FF)が標準です。
 - ポンプ出口とセパレータタンク入口との接続は、水平又はセパレータタンクに向かって下り勾配配管として下さい。
 - 封液出口配管長さは5m以内とし、大気開放として下さい。

Dimension Drawing 外形寸法図

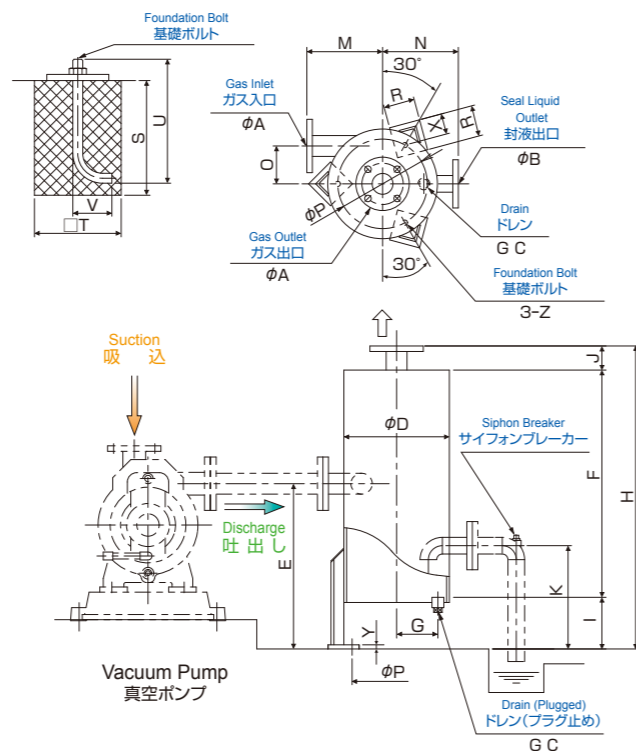

Silencer Separator Tank (DD2 type) for V
V型用 消音セパレータタンク(DD2型)

DD2型



Foundation bolt 基礎ボルト					
Z	S	T	U	V	
M12	160	110	160	50	
M16	200	140	200	63	
M20	250	170	250	80	
M24	315	210	315	100	

- Notes:
- Piping connection is JIS 10K(FF) standard.
 - Piping from outlet of the vacuum pump to separator tank should be horizontally or downward.
 - Piping of seal liquid should be exist as a length of less than 5m. Moreover, outlet of the pipe should be exposed to atmosphere.

- 注)
- 配管との接続は、JIS10K (FF)が標準です。
 - ポンプ出口とセパレータタンク入口との接続は、水平又はセパレータタンクに向かって下り勾配配管として下さい。
 - 封液出口配管長さは5m以内とし、大気開放として下さい。

Dimension Drawing 外形寸法図

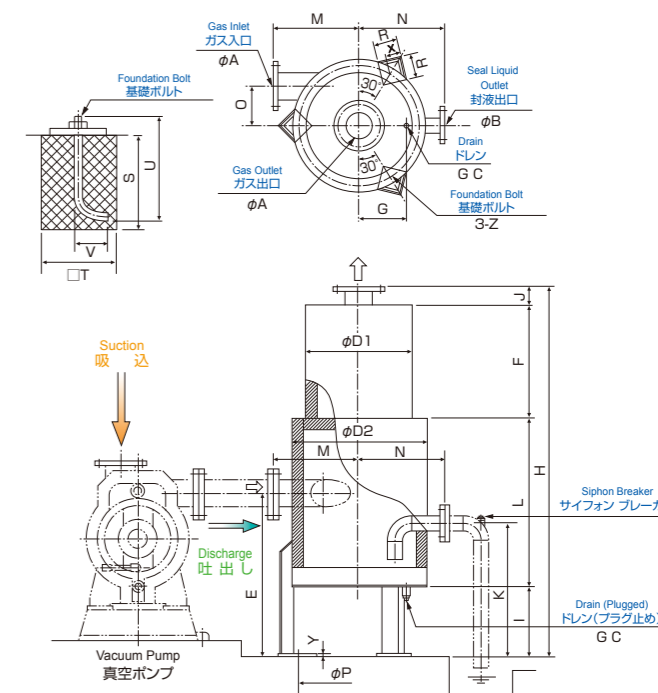

Dimensions Unit: mm 寸法表 単位:mm

Model 型式	φA	φB	C*	φD	E	F	G	H	I	J	K	M	N	O	φP	R	X	Y	Z	Approx. mass 概略質量 (kg)
DTS-40	40	25	1/2	240	420	480	90	700	150	70	340	180	180	85	200	65	45	12	M12	25
DTS-50	50	40	1/2	300	480	660	120	880	150	70	240	220	220	110	260	80	50	12	M12	35
DTS-65	65	40	1/2	340	480	580	140	800	150	70	370	240	240	120	300	80	50	12	M12	45
DTS-80	80	40	1/2	400	520	770	160	1000	150	80	250	260	260	150	360	80	50	12	M12	55
DTS-100	100	50	3/4	550	550	950	230	1180	150	80	290	340	340	210	500	100	65	12	M16	110
DTS-125	125	50	3/4	600	650	1000	250	1310	230	80	470	380	380	220	550	100	65	12	M16	130
DTS-150	150	65	1	660	680	1100	270	1440	230	100	480	400	400	240	600	100	70	12	M16	190
DTS-175	175	65	1	850	750	1300	350	1650	250	100	520	510	510	320	800	130	80	16	M20	290
DTS-200	200	80	1 1/2	1000	820	1500	400	1860	250	110	550	590	590	380	950	130	80	16	M20	380
DTS-250	250	80	1 1/2	1200	900	1600	530	2020	300	120	600	680	680	450	1150	160	95	20	M24	520

* The "C" dimensions are indicated in inches. Dimension may change in accordance with revisions and improvements. Please request detailed drawing if use for actual design purposes.
*印C寸法につきましては、表示単位はinchとなります。改良により、寸法は変更となることがあります。設計用としてご使用の場合は、別途納入図を請求ください。

Dimensions Unit: mm 寸法表 単位:mm

Model 型式	φA	φB	C*	φD1*	φD2	E	F	G	H	I	J	K	L	M	N	O	φP	R	X	Y	Z	Approx. mass 概略質量 (kg)
DD2-40	40	25	1/2	260	320	420	330	130	1000	150	70	370	450	230	230	75	290	80	50	12	M12	45
DD2-50	50	40	1/2	340	380	480	420	160	1180	150	70	400	540	250	250	105	350	80	50	12	M12	70
DD2-65	65	40	1/2	340	380	480	420	160	1180	150	70	400	540	250	250	105	350	80	50	12	M12	70
DD2-80	80	40	1/2	380	480	520	450	200	1320	150	80	410	640	300	300	150	450	80	50	12	M12	100
DD2-100	100	50	3/4	430	540	550	470	240	1410	150	80	420	710	350	350	170	500	100	65	12	M16	125
DD2-125	125	50	3/4	480	640	650	540	280	1630	230	80	500	780	380	380	200	600	100	65	12	M16	190
DD2-150	150	65	1	585	750	680	650	320	1840	230	100	510	860	450	450	240	700	100	70	12	M16	250
DD2-175	175	65	1	680	870	750	730	380	2040	250	100	570	960	520	520	280	820	130	80	16	M20	340
DD2-200	200	80	1 1/2	800	1040	820	880	450	2330	250	110	590	1090	600	600	350	1000	130	80	16	M20	450
DD2-250	250	80	1 1/2	930	1200	900	1080	530	2700	300	120	650	1200	680	680	400	1150	160	95	20	M24	700

* The "C" dimensions are indicated in inches. Dimension may change in accordance with revisions and improvements. Please request detailed drawing if use for actual design purposes.
*印C寸法につきましては、表示単位はinchとなります。改良により、寸法は変更となることがあります。設計用としてご使用の場合は、別途納入図を請求ください。

When connected the gas ejector to the liquid ring vacuum pump suction performance will be improved to a higher vacuum.

ガスエゼクタは、液封式真空ポンプ吸込側に取付けて使用し、より高真空を得ることができます。

1. High vacuum (approx. 0.8 to 8 kPa abs) can be provided.
2. The gas ejector needs no power.
3. Since the operating pressure of the liquid ring vacuum pump in the back of the gas ejector will be 10 to 15 kPa abs, to avoid the occurrence of cavitation.
 1. 高真空(0.8~8kPa abs程度)が得られます。
 2. 動力を必要としません。
 3. 後段の液封式真空ポンプの運転圧力は10~15kPa abs程度となりますので、キャビテーションの発生を避ける事ができます。

Gas Ejector (GY·GZ type) ガスエゼクタ(GY型・GZ型)

Examples of Performance ガスエゼクタの性能例

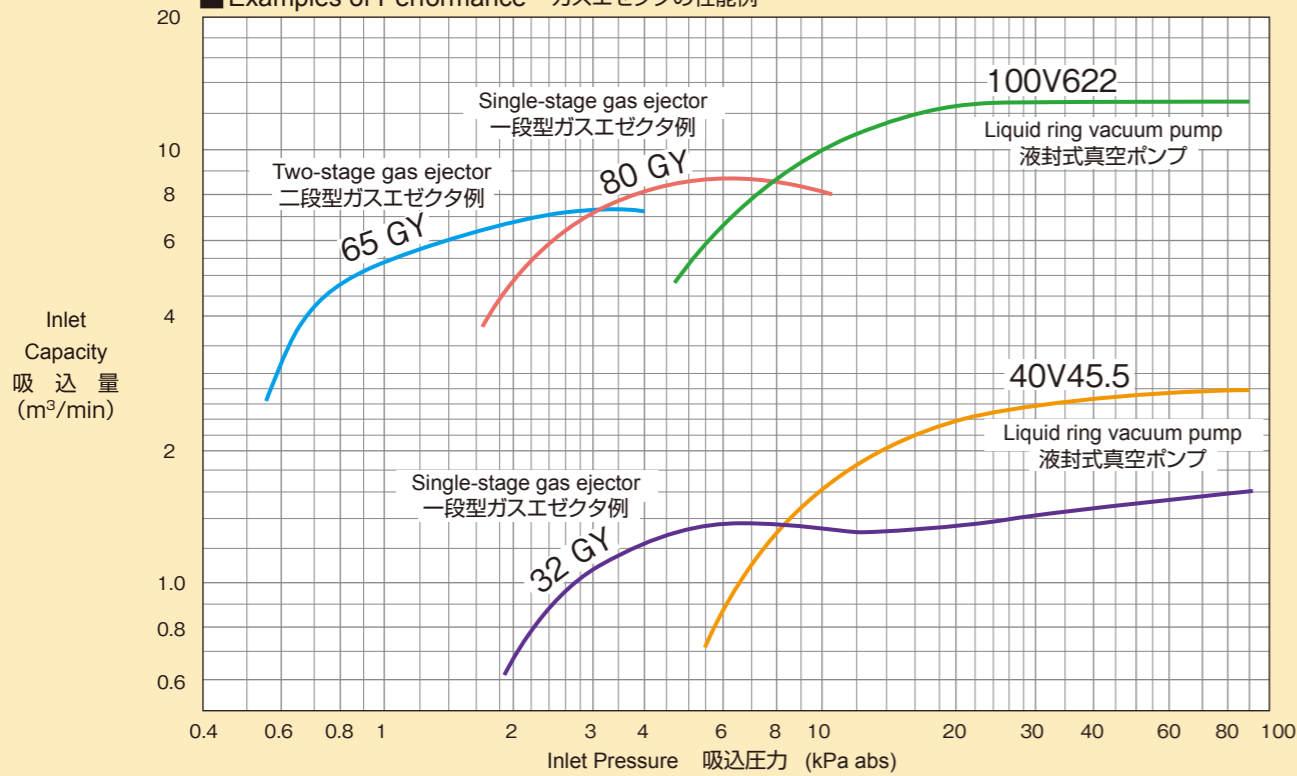

Two-stage gas ejectors are custom-designed. Please contact the nearest our VP sales division. 二段型ガスエゼクタは、別途設計となります。詳しくは弊社最寄りの弊社VP営業部までお問い合わせください。

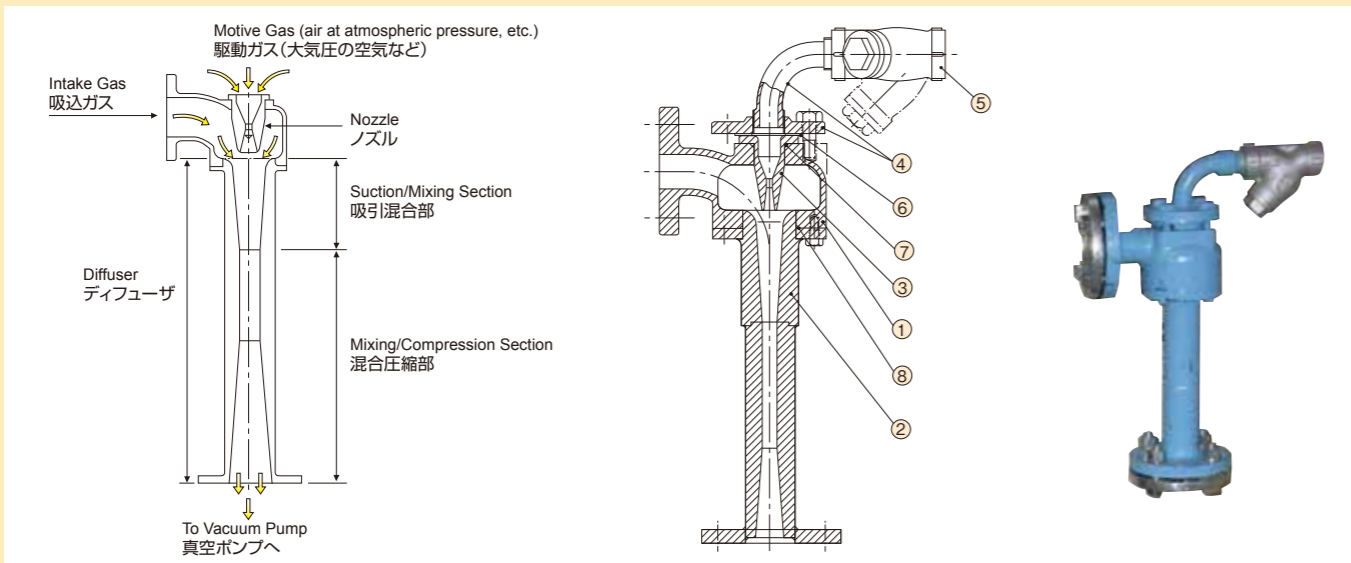

Operating Principle of Gas Ejector ガスエゼクタの作動原理

1. When the back of liquid ring vacuum pump connected to the gas ejector, motive gas is supplied through the nozzle. The motive gas is injected at a supersonic speed of the flow into the diffuser.
2. [Suction/Mixing Section] The flow of intake gas (secondary flow) caused flow along the flow motive gas (primary flow), and each of gas is mixed.
3. [Mixing/Compression Section] The motive gas and the intake gas are mixed, and this mixed gas is compressed.
4. The gas ejector sucks the intake gas along the flow of the supersonic speed in the motive gas, and will be compressed in the process of recovering the pressure by the reduction.

1. エゼクタを接続した後段の真空ポンプを運転すると、駆動ガスがノズルを通して吸込まれます。この駆動ガスはディフューザ内に超音速の流れで噴射されます。
2. 【吸引混合部】駆動ガスの流れ(一次流れ)に沿って吸込ガスの流れ(二次流れ)が生じ、吸込ガスの吸引混合がおこなわれます。
3. 【混合圧縮部】駆動ガスと吸込ガスの混合圧縮がおこなわれます。
4. エゼクタは超音速の駆動ガスに沿って吸込ガスを吸引し、減速により圧力を回復させる過程で圧縮をおこないます。

Part Description/Material List 品名・材質表

No. 品番	Part description 品名	Material 材質
1	Suction Chamber 吸入室	FC200
2	Diffuser ディフューザ	S20C/SS400
3	Nozzle ノズル	SUS304
4	Elbow and Flange エルボ及びフランジ	FCMB,FC200
5	Strainer ストレーナ	FC200/SUS304
6	Gasket シートパッキン	V#6500
7	O Ring Oリング	NBR
8	O Ring Oリング	NBR

Gas Ejector Dimensions Unit: mm ガスエゼクタ単品 寸法表 単位:mm

Model 型式	φD1	φD2	d	a	b	c	e	Approx. mass 概略質量(kg)
GY1032	32	40	3/4	110	327	193	98	13
GZ1032	32	40	3/4	110	295	193	98	13
GY2032	32	40	3/4	110	302	193	98	13
GZ2032	32	40	3/4	110	260	193	98	12
GY1040	40	50	1	120	405	242	117	17
GZ1040	40	50	1	120	366	242	117	17
GY2040	40	50	1	120	380	242	117	17
GZ2040	40	50	1	120	319	242	117	16
GY1050	50	65	1 1/4	130	500	266	138	26
GZ1050	50	65	1 1/4	130	457	266	138	26
GY2050	50	65	1 1/4	130	462	266	138	26
GZ2050	50	65	1 1/4	130	403	266	138	25
GY1065	65	80	1 1/2	140	605	283	142	40
GZ1065	65	80	1 1/2	140	564	283	142	39
GY2065	65	80	1 1/2	140	563	283	142	39
GZ2065	65	80	1 1/2	140	495	283	142	38
GY1080	80	100	2	160	730	330	169	62
GZ1080	80	100	2	160	668	330	169	60
GY2080	80	100	2	160	672	330	169	60
GZ2080	80	100	2	160	593	330	169	57
GY1081	80	125	2	160	840	330	169	67
GZ1081	80	125	2	160	778	330	169	65
GY2081	80	125	2	160	782	330	169	65
GZ2081	80	125	2	160	673	330	169	61
GY1100	100	125	2 1/2	200	960	464	203	120
GZ1100	100	125	2 1/2	200	902	464	203	118
GY2100	100	125	2 1/2	200	888	464	203	116
GZ2100	100	125	2 1/2	200	791	464	203	110
GY1101	100	150	2 1/2	200	998	464	203	126
GZ1101	100	150	2 1/2	200	930	464	203	124
GY2101	100	150	2 1/2	200	923	464	203	122
GZ2101	100	150	2 1/2	200	823	464	203	115
GY1102	100	150	2 1/2	200	1062	464	203	130
GZ1102	100	150	2 1/2	200	995	464	203	128
GY2102	100	150	2 1/2	200	974	464	203	125
GZ2102	100	150	2 1/2	200	863	464	203	120
GY1125	125	175	3	240	1165	477	239	200
GZ1125	125	175	3	240	1064	477	239	190
GY2125	125	175	3	240	1094	477	239	180
GZ2125	125	175	3	240	934	477	239	180
GY1126	125	175	3	240	1291	477	239	205
GZ1126	125	175	3	240	1207	477	239	200
GY2126	125	175	3	240	1204	477	239	185
GZ2126	125	175	3	240	1039	477	239	175

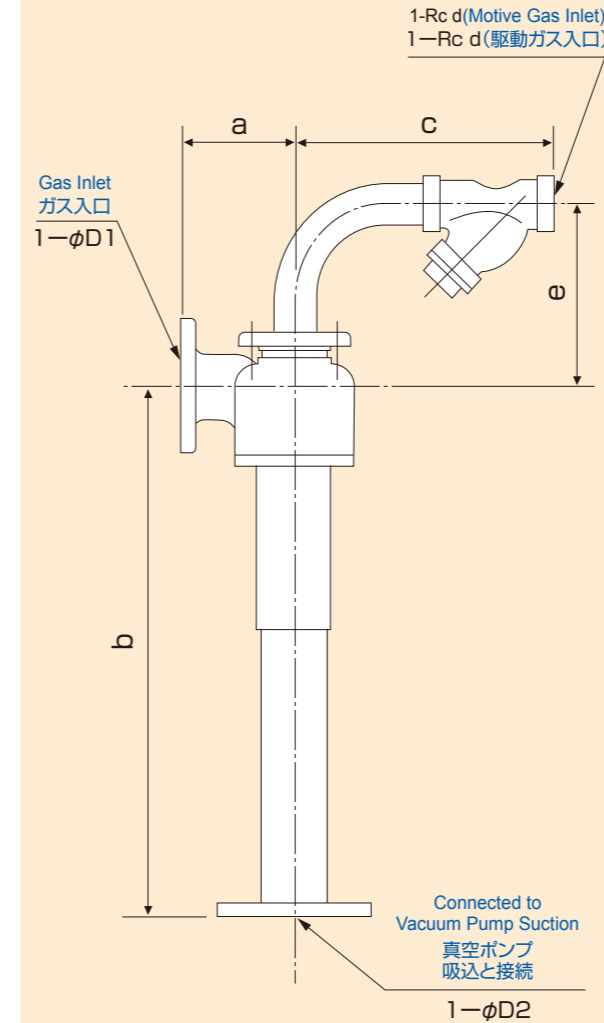

Note) Piping connection is JIS 10K (FF) standard. 注)配管との接続は、JIS 10K (FF)が標準です。

Dimension may change in accordance with revisions and improvements. Please request detailed drawing if use for actual design purposes. 改良により、寸法は変更となることがあります。設計用としてご使用の場合は、別途納入図を請求ください。

Performance Curves
性能曲線

Designed for a Seal Liquid Temperature of 15°C
封水温度15°C設計

GY1000 Model (GY1000型)

Low-Vacuum
Gas Ejector
低真空用
ガスエゼクタ
(2.5~8kPa abs)

Inlet Capacity
吸込量
(m³/min)

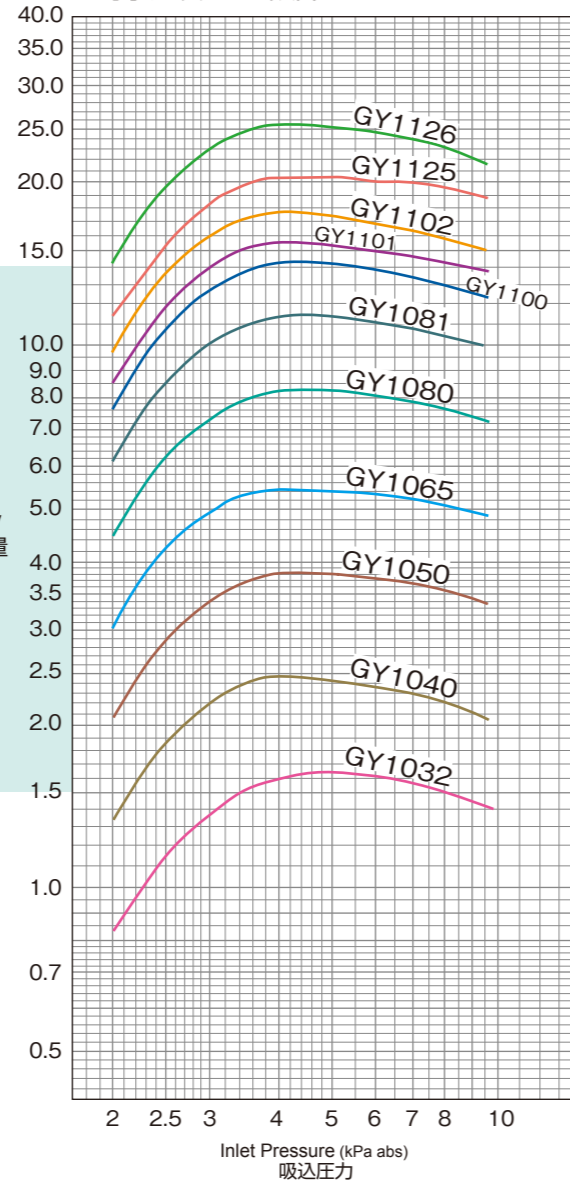

Performance Curves
性能曲線

Designed for a Seal Liquid Temperature of 30°C
封水温度30°C設計

GY2000 Model (GY2000型)

Low-Vacuum
Gas Ejector
低真空用
ガスエゼクタ
(2.5~8kPa abs)

Inlet Capacity
吸込量
(m³/min)

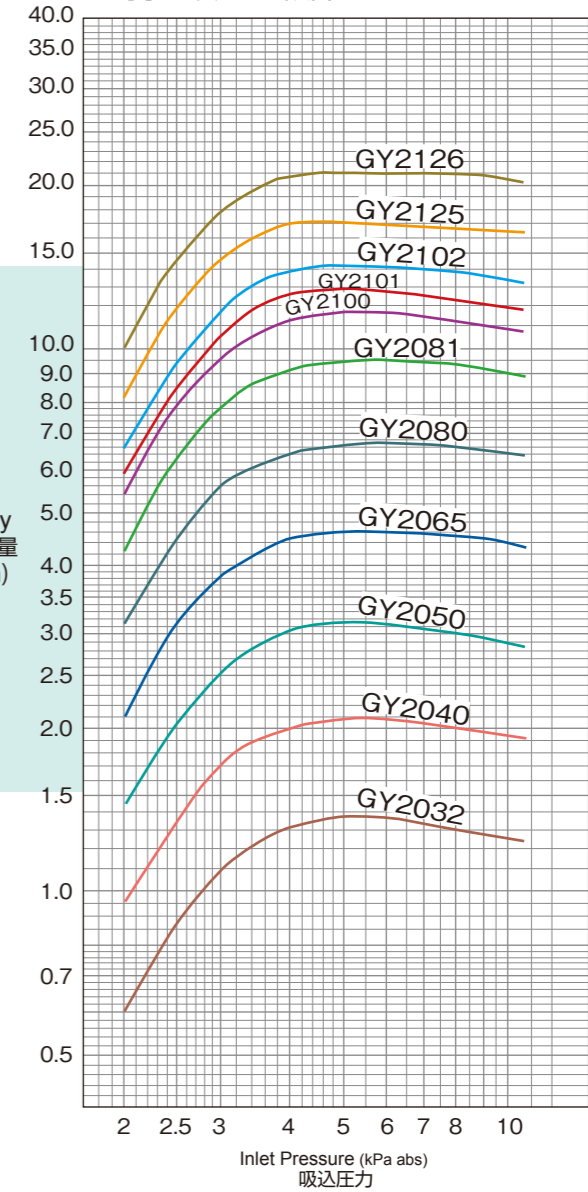

Standard Specifications (at a seal liquid temperature of 15°C)
標準仕様 (封水温度15°Cの場合)

Gas ejector model ガスエゼクタ型式	Inlet bore 吸込口径 (mm)	Inlet capacity [Inlet condition] 吸込量(吸込状態) (m³/min)							Inlet pressure 吸込圧力 (kPa abs)		Vacuum pump 真空ポンプ						
											Compatible model 適用型式	Pump model ポンプ部型式	Frequency 周波数 (Hz)	Pump speed 回転速度 (min⁻¹)	Motor output 出力 (kW)	Approx. seal liquid flow rate 概略封液量 (ℓ/min)	Combination model 組合せ型式
		0.8	2.5	3	4	5	6	8	5	6							
GY1032	32	0	1.14	1.37	1.58	1.62	1.61	1.5	40V45.5	40EV264	60	1750	5.5	25	GE40V45.5		
										40EV254	50	1450					
GY1040	40	0	1.86	2.2	2.45	2.42	2.35	2.2	50V47.5	50EV266	60	1750	7.5	30	GE50V47.5		
										50EV256	50	1450					
GY1050	50	0	2.85	3.35	3.8	3.8	3.75	3.55	65V611	65EV362	60	1150	11	35	GE65V611		
									65V411	65EV258	50	1450			GE65V411		
GY1065	65	0	4.2	4.9	5.4	5.4	5.3	5.15	80V615	80EV364	60	1150	15	40	GE80V615		
										80EV354	50	970					
GY1080	80	0	6.2	7.3	8.3	8.3	8.1	7.7	100V622	100EV366	60	1150	22	60	GE100V622		
										100EV356	50	970					
GY1081	80	0	8.5	10.1	11.3	11.3	11.1	10.5	125V630	125EV358	50		30	75	GE125V630		
									125V430V	125EV358	60				GE125V430V		
GY1100	100	0	10.7	12.7	14.1	14.1	13.8	13	125V645	125EV358	60		45	85	GE125V645		
									125V445V	125EV358	50				GE125V445V		
GY1101	100	0	11.8	14	15.5	15.2	15	14.2	150V837	150EV466	60		37	85	GE150V837		
									150V437V	150EV466	50-60				GE150V437V		
GY1102	100	0	13.6	16	17.6	17.5	16.9	15.9	150V645	150EV466	50		45	85	GE150V645		
									150V445V	150EV466	60				GE150V445V		
GY1125	125	0	15.3	18.2	20.5	20.5	20.2	19.5	175V855	175EV456	50		55	120	GE175V855		
									175V455V	175EV456	50-60				GE175V455V		
GY1126	125	0	19.5	23	25.5	25.5	24.5	23	175V875	175EV456	60		75	120	GE175V875		
									175V475V	175EV456	50-60				GE175V475V		

Separate consideration is required for gases (other than air) with a different specific gravity. Contact our VP sales division for more information.
空気以外で比重が異なる場合は、特別対応となります。別途弊社VP営業部までお問い合わせください。

Standard Specifications (at a seal liquid temperature of 30°C)
標準仕様 (封水温度30°Cの場合)

Gas ejector model ガスエゼクタ型式	Inlet bore 吸込口径 (mm)	Inlet capacity [Inlet condition] 吸込量(吸込状態) (m³/min)							Inlet pressure 吸込圧力 (kPa abs)		Vacuum pump 真空ポンプ						
											Compatible model 適用型式	Pump model ポンプ部型式	Frequency 周波数 (Hz)	Pump speed 回転速度 (min⁻¹)	Motor output 出力 (kW)	Approx. seal liquid flow rate 概略封液量 (ℓ/min)	Combination model 組合せ型式
		0.93	2.5	3	4	5	6	8	5	6							
GY2032	32	0	0.87	1.1	1.32	1.38	1.37	1.3	40V45.5	40EV264	60	1750	5.5	20	GE40V45.5		
										40EV254	50	1450					
GY2040	40	0	1.39	1.72	2	2.09	2.08	2	50V47.5	50EV266	60	1750	7.5	25	GE50V47.5		
										50EV256	50	1450					
GY2050	50	0	2.08	2.55	3.05	3.15	3.12	3	65V611	65EV362	60	1150	11	30	GE65V611		
									65V411	65EV258	50	1450			GE65V411		
GY2065	65	0	3.15	3.85	4.5	4.65	4.6	4.5	80V615	80EV364	60	1150	15	35	GE80V615		
										80EV354	50	970					
GY2080	80	0	4.5	5.6	6.5	6.7	6.75	6.6	100V622	100EV366	60	1150	22	50	GE100V622		
										100EV356	50	970					
GY2081	80	0	6.3	7.8	9.2	9.5	9.5	9.3	125V630	125EV358	50		30	60	GE125V630		
									125V430V	125EV358	60				GE125V430V		
GY2100	100	0	7.9	9.7	11.3	11.8	11.7	11.2	125V645	125EV358	60		45	70	GE125V645		
									125V445V	125EV358	50				GE125V445V		
GY2101	100	0	8.5	10.6	12.6	13	12.8	12.3	150V837	150EV466	60		37	70	GE150V837		
									150V437V	150EV466	50-60				GE150V437V		
GY2102	100	0	9.5	11.9	14	14.3	14.2	13.9	150V645	150EV466	50		45	70	GE150V645		
									150V445V	150EV466	60				GE150V445V		
GY2125	125	0	12	14.7	17	17.1	17	16.8	175V855	175EV456	50		55	100	GE175V855		
									175V455V	175EV456	50-60				GE175V455V		
GY2126	125	0	14.8	18	21	21.2	21.2	21	175V875	175EV456	60		75	100	GE175V875		
									175V475V	175EV456	50-60				GE175V475V		

Separate consideration is required for gases (other than air) with a different specific gravity. Contact our VP sales division for more information.
空気以外で比重が異なる場合は、特別対応となります。別途弊社VP営業部までお問い合わせください。

Performance Curves
性能曲線

Designed for a Seal Liquid Temperature of 15°C
封水温度15°C設計

GZ1000 Model (GZ1000型)

High-Vacuum Gas Ejector
高真空用ガスエゼクタ
(1.2~3.5kPa abs)

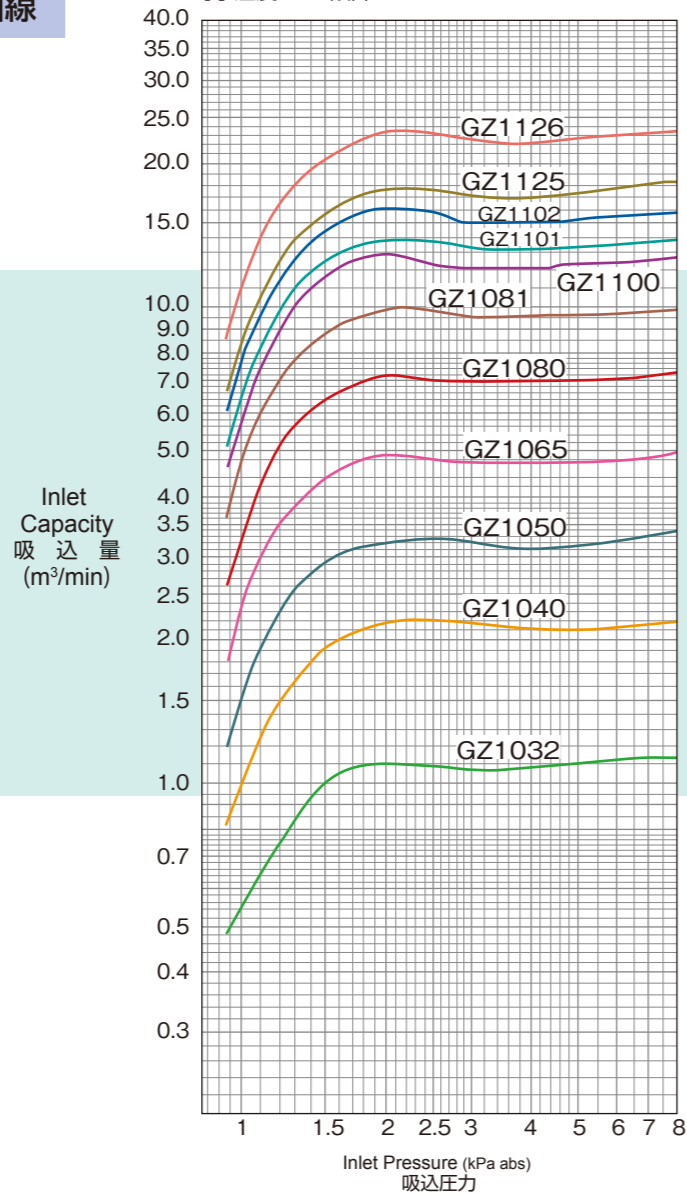

Performance Curves
性能曲線

Designed for a Seal Liquid Temperature of 30°C
封水温度30°C設計

GZ2000 Model (GZ2000型)

High-Vacuum Gas Ejector
高真空用ガスエゼクタ
(1.2~3.5kPa abs)

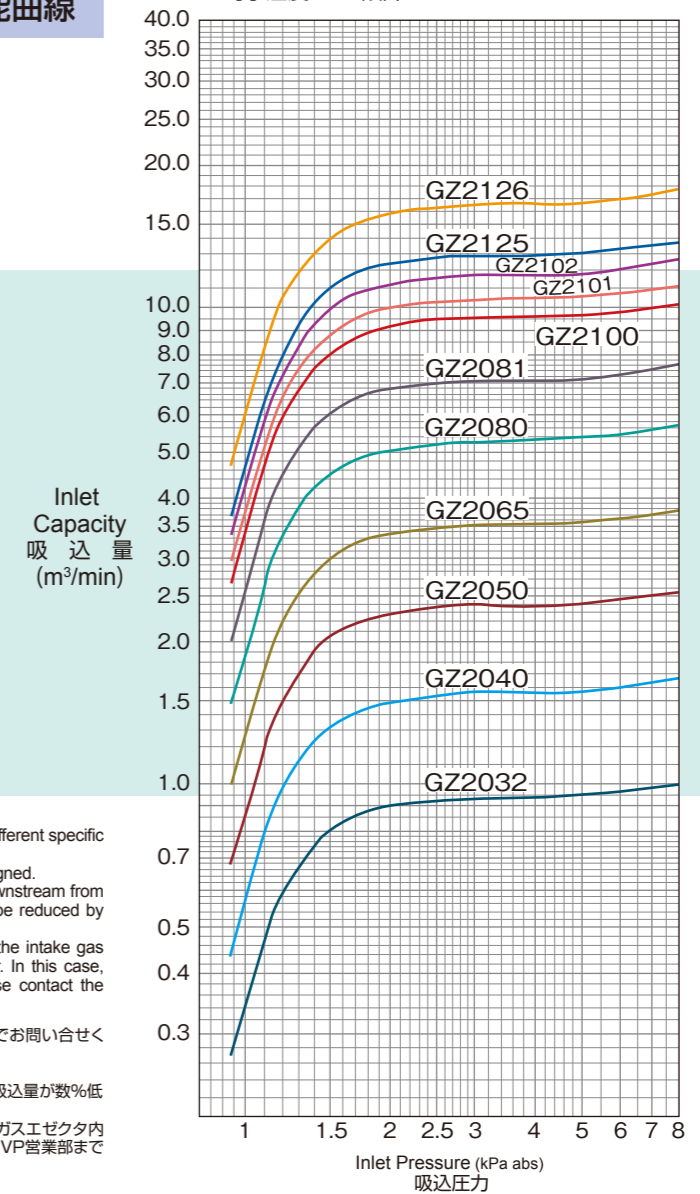

1. Separate consideration is required for gases (other than air) with a different specific gravity. Contact us for more information.
2. Inlet pressure of up to approx. 0.4 kPa abs (at 0 suction) can be designed.
3. If both the impeller and port plate in the liquid ring vacuum pump downstream from the gas ejector are made of stainless steel, suction capacity may be reduced by several percent.
4. If the temperature of the driver gas is near the freezing point and the intake gas contains water vapor, the driver gas may freeze in the gas ejector. In this case, measures to prevent the gas from freezing must be taken. Please contact the nearest our VP sales division for detail.

- (1) 取扱ガスが空気以外で比重が異なる場合は詳細な検討が必要ですのでお問い合わせください。
- (2) 到達吸入圧力(吸入量0の時)約0.4kPa abs迄は製作可能です。
- (3) 後段液封式真空ポンプの材質が羽根車・仕切板共にステンレスの場合、吸入量が数%低下することがあります。
- (4) 水蒸気を含むガスを吸引する場合は、駆動ガス温度が氷点近くの時はガスエゼクタ内で氷結することがあり防止策が必要です。この様な場合は最寄りの弊社VP営業部までお問い合わせください。

Standard Specifications (at a seal liquid temperature of 15°C)
標準仕様 (封水温度15°Cの場合)

Gas ejector model ガスエゼクタ型式	Inlet bore 吸入口径 (mm)	Inlet capacity [Inlet condition] 吸入量(吸入状態) (m³/min)					Inlet pressure 吸入圧力 (kPa abs)			Vacuum pump 真空ポンプ						
		0.53	0.6	1.2	1.5	2	2.5	3	3.5	Compatible model 適用型式	Pump model ポンプ部型式	Frequency 周波数 (Hz)	Pump speed 回転速度 (min⁻¹)	Motor output 出力 (kW)	Approx. seal liquid flow rate 概略封液量 (ℓ/min)	Combination model 組合せ型式
GZ1032	32	—	0	0.75	1	1.1	1.09	1.08	1.08	40V45.5	40EV264 40EV254	60 50	1750 1450	5.5	30	GE40V45.5
GZ1040	40	—	0	1.5	1.93	2.15	2.2	2.15	2.12	50V47.5	50EV266 50EV256	60 50	1750 1450	7.5	35	GE50V47.5
GZ1050	50	—	0	2.3	2.95	3.2	3.25	3.21	3.15	65V611 65V411	65EV362 65EV258	60 50	1150 1450	11	45	GE65V611 GE65V411
GZ1065	65	0	—	3.5	4.4	4.85	4.8	4.7	4.7	80V615	80EV364 80EV354	60 50	1150 970	15	50	GE80V615
GZ1080	80	0	—	5.1	6.4	7.15	7	6.9	6.9	100V622	100EV366 100EV356	60 50	1150 970	22	75	GE100V622
GZ1081	80	0	—	7	8.9	9.8	9.7	9.5	9.5	125V630 125V430V	125EV358 125EV358	50 60	970	30	90	GE125V630 GE125V430V
GZ1100	100	0	—	9	11.5	12.9	12.3	12	12	125V645 125V445V	125EV358 125EV358	60 50	1150	45	105	GE125V645 GE125V445V
GZ1101	100	0	—	9.9	12.5	13.8	13.8	13.2	13	150V837 150V437V	150EV466 150EV466	60 50-60	870	37	105	GE150V837 GE150V437V
GZ1102	100	0	—	11.3	14.4	16	15.8	15	14.9	150V645 150V445V	150EV466 150EV466	50 60	970	45	105	GE150V645 GE150V445V
GZ1125	125	0	—	12.6	15.9	17.6	17.6	17	16.9	175V855 175V455V	175EV456 175EV456	50 50-60	730-710	55	150	GE175V855 GE175V455V
GZ1126	125	0	—	16.7	20.9	23.1	23.1	22.2	22	175V875 175V475V	175EV456 175EV456	60 50-60	870	75	150	GE175V875 GE175V475V

Separate consideration is required for gases (other than air) with a different specific gravity. Contact our VP sales division for more information.
空気以外で比重が異なる場合は、特別対応となります。別途弊社VP営業部までお問い合わせください。

Standard Specifications (at a seal liquid temperature of 30°C)
標準仕様 (封水温度30°Cの場合)

Gas ejector model ガスエゼクタ型式	Inlet bore 吸入口径 (mm)	Inlet capacity [Inlet condition] 吸入量(吸入状態) (m³/min)					Inlet pressure 吸入圧力 (kPa abs)			Vacuum pump 真空ポンプ					
		0.6	1.2	1.5	2	2.5	3	3.5	Compatible model 適用型式	Pump model ポンプ部型式	Frequency 周波数 (Hz)	Pump speed 回転速度 (min⁻¹)	Motor output 出力 (kW)	Approx. seal liquid flow rate 概略封液量 (ℓ/min)	Combination model 組合せ型式
GZ2032	32	0	0.6	0.8	0.9	0.93	0.93	0.94	40V45.5	40EV264 40EV254	60 50	1750 1450	5.5	30	GE40V45.5
GZ2040	40	0	1	1.32	1.48	1.54	1.56	1.57	50V47.5	50EV266 50EV256	60 50	1750 1450	7.5	35	GE50V47.5
GZ2050	50	0	1.53	2.05	2.29	2.33	2.35	2.37	65V611 65V411	65EV362 65EV258	60 50	1150 1450	11	45	GE65V611 GE65V411
GZ2065	65	0	2.23	3	3.39	3.49	3.51	3.52	80V615	80EV364 80EV354	60 50	1150 970	15	50	GE80V615
GZ2080	80	0	3.35	4.5	5.05	5.2	5.25	5.25	100V622	100EV366 100EV356	60 50	1150 970	22	70	GE100V622
GZ2081	80	0	4.5	6.1	6.8	7	7.05	7.05	125V630 125V430V	125EV358 125EV358	50 60	970	30	85	GE125V630 GE125V430V
GZ2100	100	0	6	8.1	9.1	9.4	9.5	9.5	125V645 125V445V	125EV358 125EV358	60 50	1150	45	100	GE125V645 GE125V445V
GZ2101	100	0	6.5	8.8	9.9	10.2	10.3	10.3	150V837 150V437V	150EV466 150EV466	60 50-60	870	37	100	GE150V837 GE150V437V
GZ2102	100	0	7.3	10	11.2	11.5	11.7	11.7	150V645 150V445V	150EV466 150EV466	50 60	970	45	100	GE150V645 GE150V445V
GZ2125	125	0	8.2	11	12.4	12.8	12.9	12.9	175V855 175V455V	175EV456 175EV456	50 50-60	730-710	55	140	GE175V855 GE175V455V
GZ2126	125	0	10.5	14	15.8	16.2	16.3	16.5	175V875 175V475V	175EV456 175EV456	60 50-60	870	75	140	GE175V875 GE175V475V

Separate consideration is required for gases (other than air) with a different specific gravity. Contact our VP sales division for more information.
空気以外で比重が異なる場合は、特別対応となります。別途弊社VP営業部までお問い合わせください。

Influence of the Seal Water Temperature 封水温度の影響

●With liquid ring pumps, the seal liquid temperature increases and the vapor pressure is raised, the gas space in the pump is filled with seal liquid vapor. Therefore suction capacity is reduced especially the high vacuum range.

液封式ポンプでは、ポンプ内空間部を封液蒸気が占めているため、封液温度が高くなって蒸気圧が大きくなると、特に高真空では吸込量が低下します。

●The estimated suction capacity is based on operation at a seal liquid temperature of 15°C. (Q15) Determine the change rate (K) with the chart below, and use the following formula to calculate the suction capacity (Qt) at a seal liquid temperature of t°C. (The following chart is based on actual measurement values.) Suction capacity $Q_t = K \times Q_{15}$ [m³/min]

想定仕様の吸込量は15°Cの封水で運転する時のものです (Q15)。封水温度t°Cの時の吸込量Qtは、下図より変化率Kを求め、次式により計算します。(この図は当社の実測値により作成したものです。)

吸込量 $Q_t = K \times Q_{15}$ (m³/min)

●Especially when the seal liquid temperature is 30°C or lower, the change rate is approximately expressed with the following formula:
特に封水温度30°C以下の場合、変化率は概略次式で表わせます。

$$\text{Change rate } K = \frac{P_s - P_v t^\circ\text{C}}{P_s - P_v 15^\circ\text{C}} \quad \text{変化率 } K = \frac{P_s - P_v t^\circ\text{C}}{P_s - P_v 15^\circ\text{C}}$$

Wherein, "Ps" is the inlet pressure (kPa abs), and "Pv" is the vapor pressure (kPa).

ここでPs: 吸込圧力(kPa abs), Pv: 水蒸気圧(kPa)

●When using a seal liquid other than water, you can approximate the suction capacity change rate by referring to the performance curves for the water temperature that corresponds to the relevant vapor pressure.

尚、水以外の液体の場合には、目安として同じ蒸気圧の水温のカーブを使用すれば、吸込量の変化率が得られます。

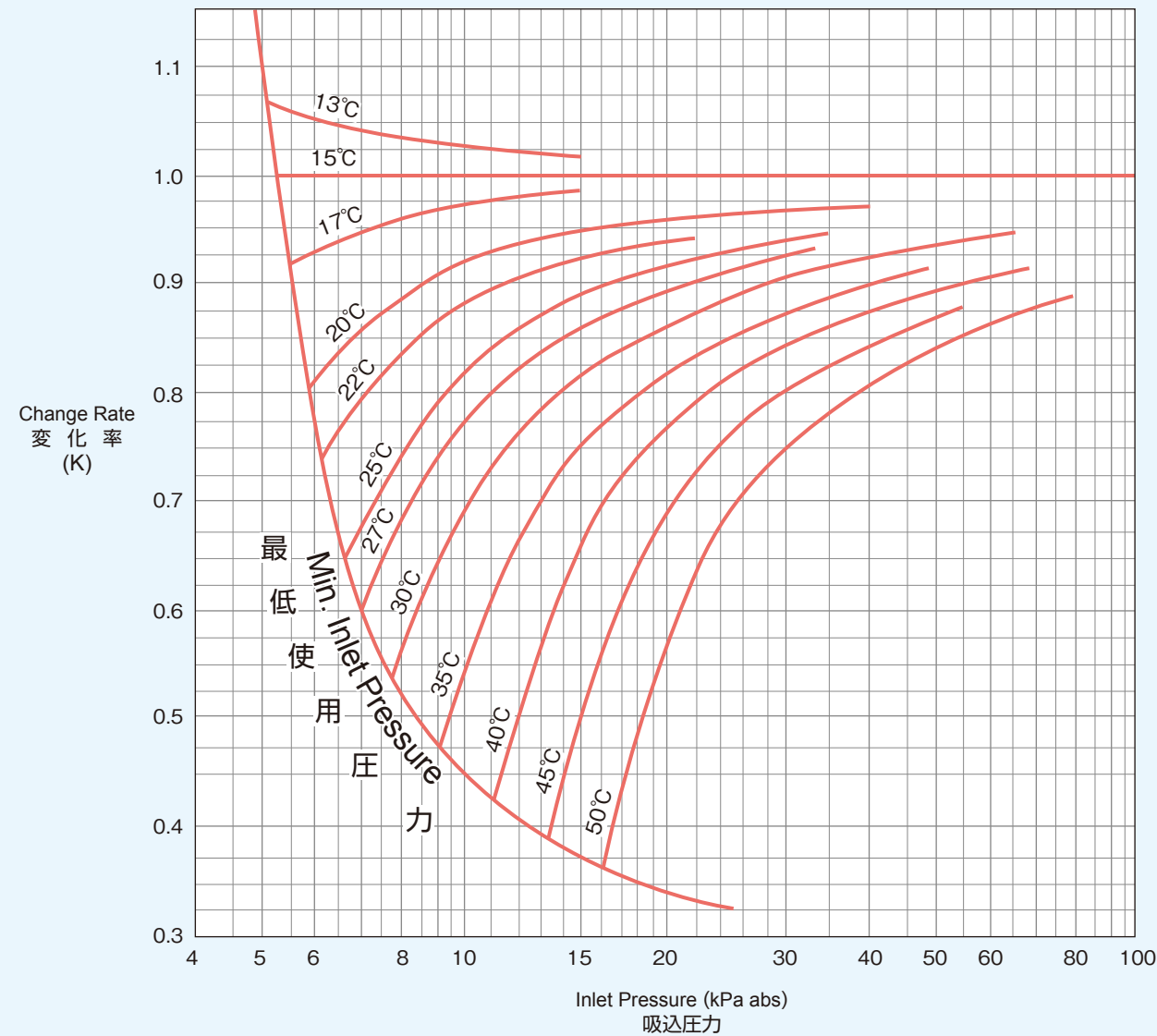

Water Vapor Pressure unit: kPa 水の蒸気圧 単位: kPa

t°C	0	1	2	3	4	5	6	7	8	9
0	0.611	0.657	0.706	0.758	0.813	0.872	0.935	1.002	1.073	1.148
10	1.228	1.312	1.402	1.497	1.598	1.705	1.818	1.937	2.063	2.197
20	2.338	2.487	2.643	2.809	2.983	3.167	3.361	3.565	3.78	4.005
30	4.243	4.492	4.755	5.03	5.319	5.623	5.941	6.275	6.625	6.992
40	7.376	7.778	8.199	8.639	9.101	9.583	10.09	10.61	11.16	11.74
50	12.33	12.96	13.61	14.29	15	15.74	16.51	17.31	18.14	19.01
60	19.92	20.86	21.83	22.85	23.91	25	26.14	27.33	28.55	29.83

Evacuation Time Characteristics 排気時間特性

Evacuation Time for the Enclosed Space 密閉容器の排気時間について

When using a liquid ring vacuum pump equipped with gas ejector, the following three types of evacuation methods are available: ガスエゼクタ付液封式真空ポンプの場合、排気の方法は下記の3通りがあります。

- ① The gas ejector is operated in conjunction with the liquid ring vacuum pump, without a bypass pipe connected. **Evacuation time is longest, but no valve operation is required.**
バイパス配管を設けず、最初からガスエゼクタと液封式真空ポンプを連動させる。排気時間は一番長いですが、バルブの操作は一切不要となります。
- ② The liquid ring vacuum pump is operated first, and the gas ejector is then operated at certain inlet pressure, without a bypass pipe connected. **Evacuation time is slightly reduced, but operation of a single valve (valve A) is required.**
バイパス配管を設けず、最初は液封式真空ポンプを起動させ、ある吸込圧でガスエゼクタを連動させる。排気時間は若干短くなりますが、バルブ(A)の操作が1カ所必要となります。
- ③ The liquid ring vacuum pump is operated first, and the gas ejector is then operated at certain inlet pressure, with a bypass pipe connected. **Evacuation time is shortest, but operation of two valves (valves A and B) is required.**
バイパス配管を設け、最初は液封式真空ポンプを起動させ、ある吸込圧でガスエゼクタを連動させる。排気時間は一番短くなりますが、バルブ(A、B)の操作が2カ所必要となります。

Graph 1 shows the performance curves of the liquid ring vacuum pump equipped with gas ejector (combination of GY2080 and 100V622). Curves ①, ② and ③ in this graph correspond to methods ①, ② and ③ above.

In the inlet pressure range of approx. 101.3 to 12 kPa abs, Inlet capacity ① is lower than ③ due to the gas ejector driver gas flow rate and the resistance in the narrowed portion of the diffuser. Inlet capacity ② is also lower than that of ③, also due to the resistance in the narrowed portion of the diffuser.

Graph 1はGY2080+100V622の組合せのガスエゼクタ付液封式真空ポンプの性能曲線です。グラフ中の①、②、③は上記に対応します。即ち、吸込圧101.3kPa abs~12kPa abs程度迄は③に比べ①はガスエゼクタの駆動ガス量とディフューザの細まり部の抵抗分が、②はガスエゼクタのディフューザの細まり部の抵抗分がある為、吸込量はそれぞれ低下しています。

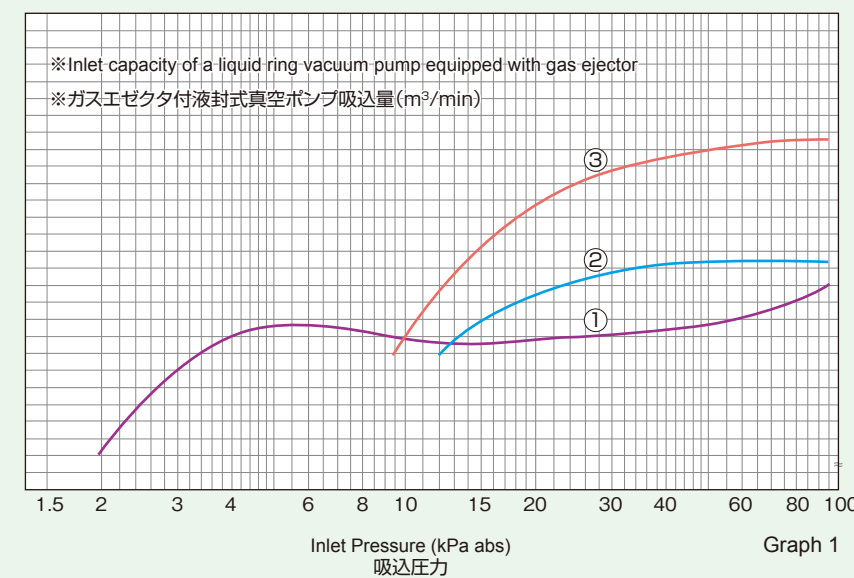

Graph 2 shows the 100 m³ enclosed space evacuation time based on calculation with the performance curves ①, ② and ③ in Graph 1. (Air leakage: 0)

Graph 2は100m³の密閉容器の排気時間をGraph 1の①、②、③の性能曲線で計算したものです。(漏れ空気0)。

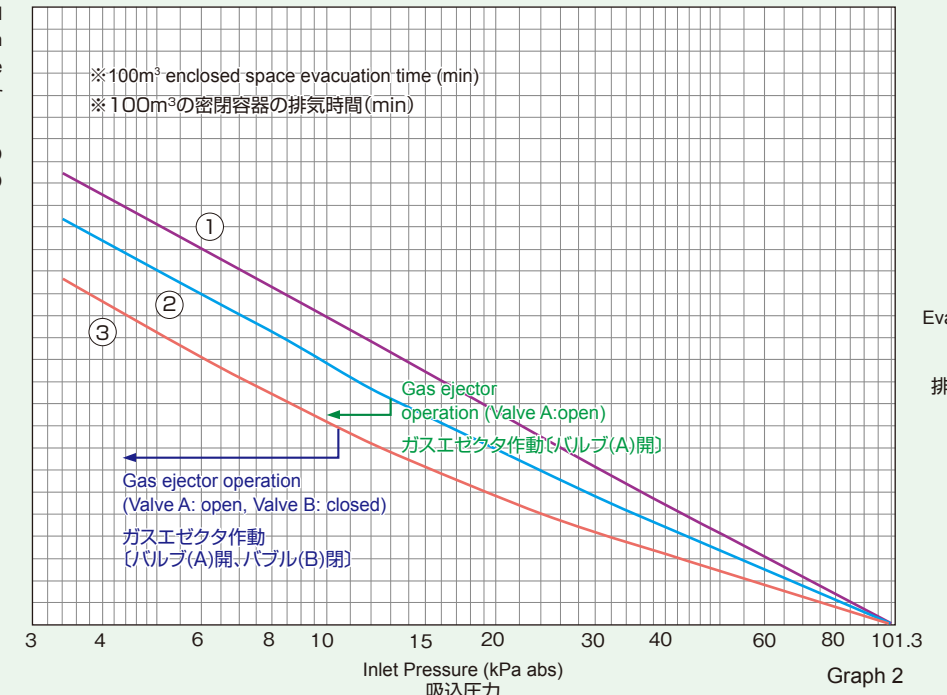

Evacuation Time (min) 排気時間

Graph 2

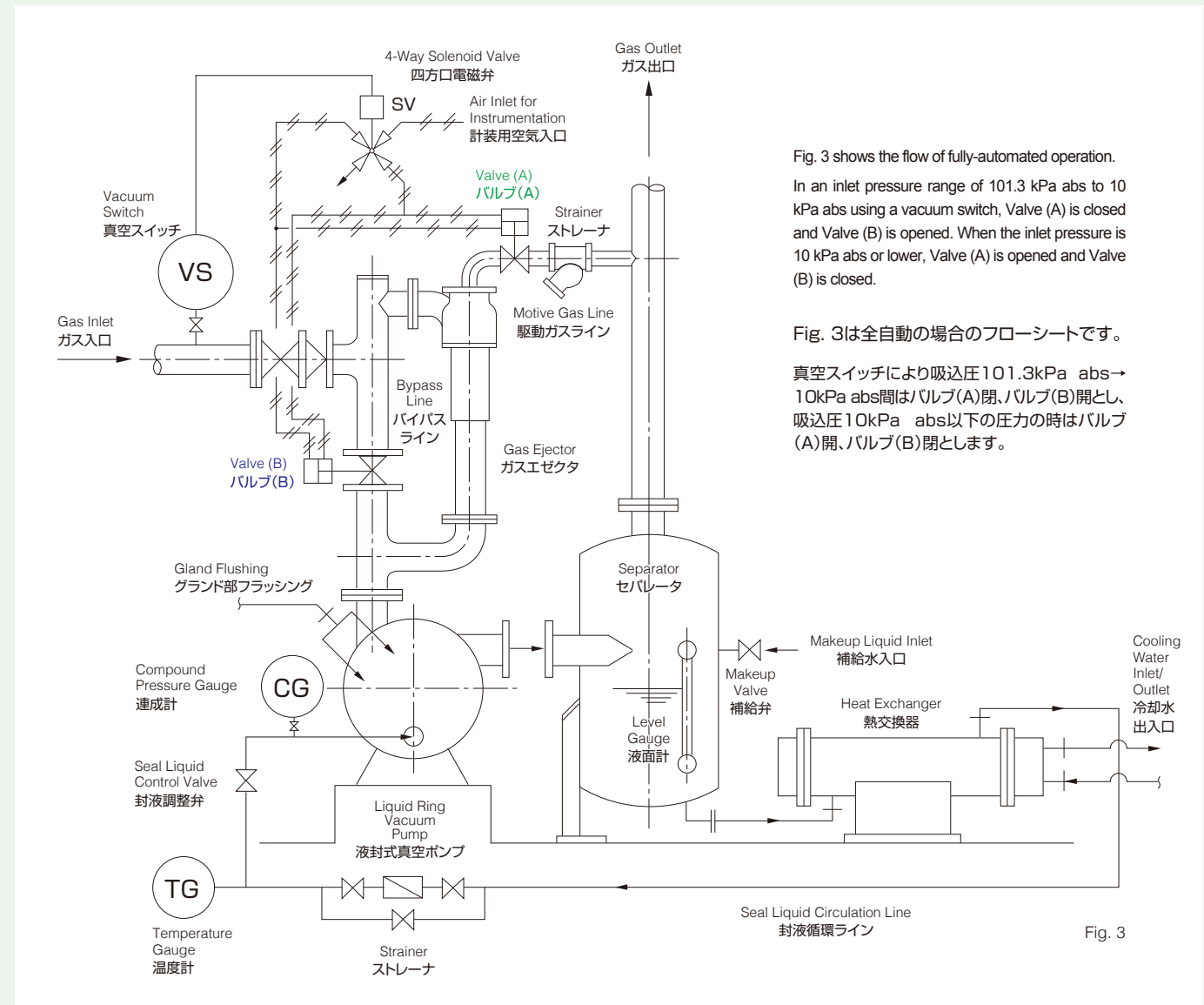

Fig. 3 shows the flow of fully-automated operation. In an inlet pressure range of 101.3 kPa abs to 10 kPa abs using a vacuum switch, Valve (A) is closed and Valve (B) is opened. When the inlet pressure is 10 kPa abs or lower, Valve (A) is opened and Valve (B) is closed.

Fig. 3は全自動の場合のフローシートです。真空スイッチにより吸込圧101.3kPa abs→10kPa abs間はバルブ(A)閉、バルブ(B)開とし、吸込圧10kPa abs以下の圧力の時はバルブ(A)開、バルブ(B)閉とします。

Fig. 3