

# LH-W

The slim pumps that can be installed in a smaller pipe. Ideal for deep-well pre-dewatering. A dual impeller has greatly increased the pumping power to realize high-head specifications. (Model LH33.0 is a single impeller pump.)



LH23.0W

## Performance Curves

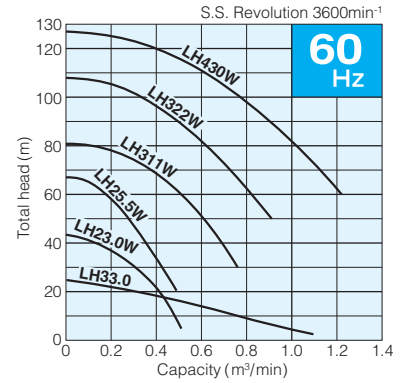
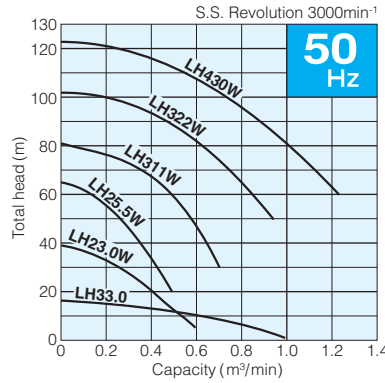

## Major Standard Specifications

Item	Outlet Bore(mm)	50	80	100
Pumping Liquid	Type of Liquid	Rain Water, Ground Water, Sand Laden Water		
	Liquid Temperature	0~40°C		
Pump	Components	Impeller	LH23.0W & LH33.0 - Semi-open Other Models - Closed	
		Shaft Seal	Double Mechanical Seal Water Pressure Endurance	
		Bearing	Double Shielded Pre-Lubricated Ball Bearing	
	Material	Impeller	Chromium Iron Casting	
		Pump Casing	LH23.0W & LH33.0 - Ductile Iron Casting Other Models - Gray Iron Casting	
	Shaft Seal	Silicon Carbide		
Motor	Type, poles	Dry Type, Induction Motor, 2-pole		
	Class of Insulation	LH23.0W, LH33.0, LH430W - class F LH25.5W, LH311W, LH322W - class B		
	Phase / Voltage	3-phase, 220V, 380V, 400V, 415V, 440V, 460V, 525V, 575V		
	Motor Protector (Built in)	Circle Thermal Protector (excl. LH430W) LH430W - Miniature Thermal Protector		
	Lubricant	Turbine Oil ISO VG32		
	Material	Frame	Gray Iron Casting	
Shaft		420 stainless Steel		
Cable		Chloroprene Rubber		
Discharge Connection		LH23.0W - Threaded Hose Connection (BSPT or NPT*)		
		LH25.5W, LH311W - JIS 10K Flange		
		LH322W, LH430W - JIS 20K Flange		

※When ordering, please specify BSPT or NPT.

## Specifications 50/60Hz

Discharge Bore (mm)	Model	Motor Output (kW)	Phase	Total Head (m)	Capacity (m³/min.)	Starting Method	Dry Weight (kg)	Length of Cable (m)
50	LH23.0W	3	3-phase	32 / 35	0.2	DOL	46	20
	LH25.5W	5.5		46	0.3		80	
80	LH311W	11		59 / 61	0.5		130	
	LH322W	22		82	0.6		304	
100	LH430W	30		102 / 105	0.7	Star-Delta	324	

### Single-Stage Model

80	LH33.0	3.0	3-phase	12 / 15	0.5	DOL	42	20
----	--------	-----	---------	---------	-----	-----	----	----

•Dry weight of the pump excluding cable.

## Dimensions

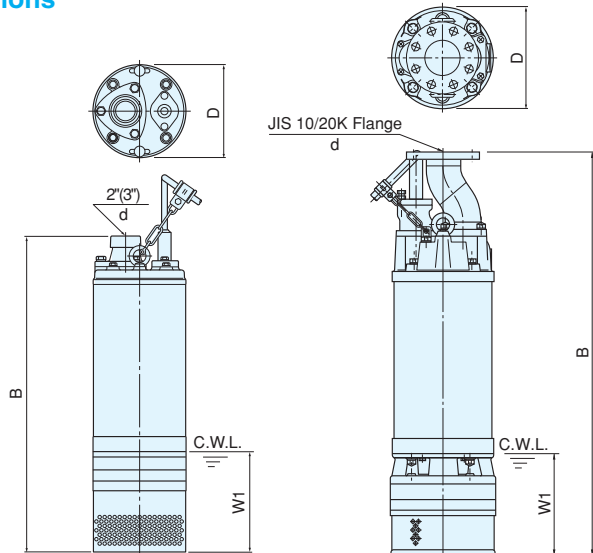

※ ( ) : LH33.0 Version

C.W.L.: Continuous Running Water Level

Unit:mm

## Standard Accessories

- One 20m Long Power Cable
- Discharge Connection (Thread Connection or Flange)
- Galvanized Corrosion Protection Anodes (except 3kW models)

## Optional Accessories

- Extended Cable
- Cathodic Protection Plates (3.0kW models only)
- Centered Discharge (JIS 10K) Flange (3.0kW models only)
- Special Paint

Model	d	B	D	W1
LH23.0W	50	630	185	200
LH25.5W	50	750	244	170
LH311W	80	1024	270	200
LH322W	80	1235	330	300
LH430W	100	1375	365	300

### Single-Stage Model

LH33.0	80	645	185	150
--------	----	-----	-----	-----