

### Probe type automatic pump (KTVE model)

Unit is turned on/off by probe-type water level sensor to prevent draught water flow when the water level drops.

Enhances durability of the pump itself by reducing radical part wear while saving energy.

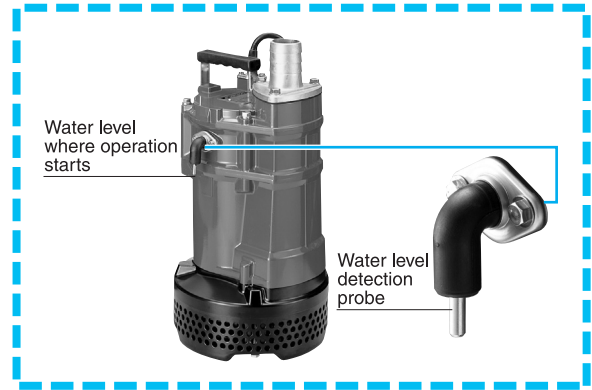

### Major Standard Specifications

Item		Discharge bore (mm)		50	80
Pumping fluid	Type of fluid	Rain water, Ground water, Sand carrying water			
	Liquid temperature	0 ~ 40°C			
Pump	Components	Impeller	Semi-vortex		
		Shaft seal	Double mechanical seal		
		Bearing	Shielded ball bearing		
	Materials	Impeller	Synthetic rubber(0.75kW) Ductile iron casting		
		Casing	Synthetic rubber		
Shaft seal (mechanical seal)	Silicon carbide				
Motor	Type, Poles	Dry-type submersible induction motor, 2 poles			
	Insulation	Class E			
	Phase / Voltage	Three-phase / 220V, 380V, 400V, 415V, 440V, 460V			
	Motor protector(Built-in)	Circle thermal protector			
	Lubricant	Turbine oil (ISO VG32)			
	Materials	Frame	Aluminum alloy casting		
Shaft		Stainless steel #420 / #403			
Cable		PVC Chloroprene rubber			
Discharge connection		Hose coupling			

### Performance Curves

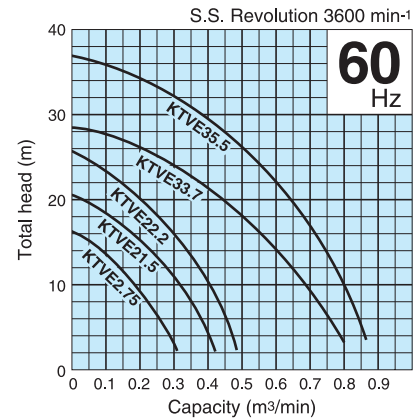
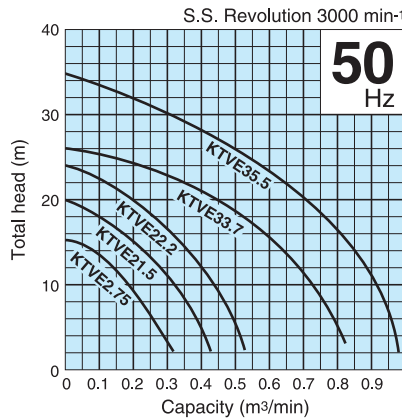

### Specifications 50/60Hz

Discharge Bore mm	Model	Motor Output kW	Phase	Total Head m	Capacity m³/min	Starting Method	Dry Weight kgs	Length of Cable m
50	KTVE2.75	0.75	Three-phase	10	0.18	D.O.L.	12.7	5
50	KTVE21.5	1.5	Three-phase	15	0.20	D.O.L.	21.5	8
50	KTVE22.2	2.2	Three-phase	20	0.20	D.O.L.	24.5	8
80	KTVE33.7	3.7	Three-phase	18	0.50	D.O.L.	39.5	8
80	KTVE35.5	5.5	Three-phase	22	0.60	D.O.L.	52.0	8

• Dry weight of the pump excluding cable.

### Standard Accessories

- Cabtyre cable ..... 1 pc
- Hose coupling ..... 1 pc
- Hose band (0.75kW only)..... 1 pc

### Optional Specifications

- Extended cable
- Special paint

### Dimensions Unit:mm

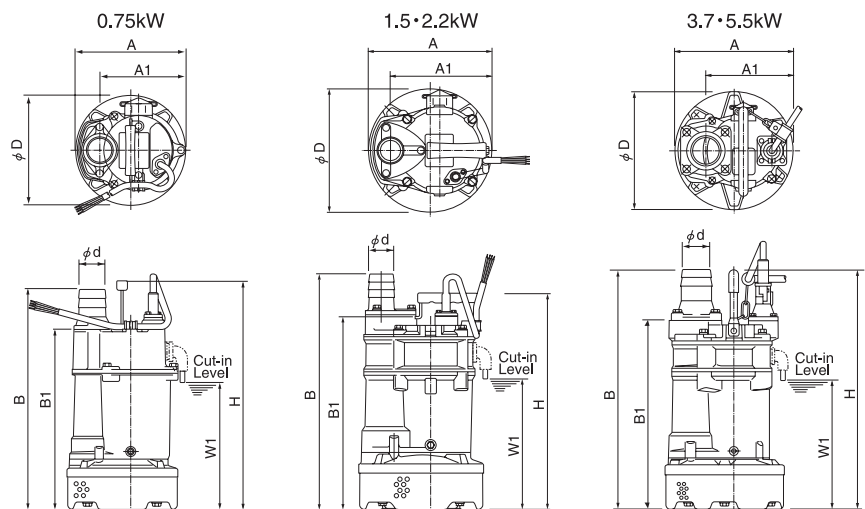

Model	d	A	A1	B	B1	D	H	W1
KTVE2.75	50	200	155	401	329	200	417	234
KTVE21.5	50	240	187	462	380	240	426	266
KTVE22.2	50	240	187	462	380	240	426	266
KTVE33.7	80	285	210	585	462	285	585	327
KTVE35.5	80	300	229	620	497	300	620	357